

GSE 300

Economical granulators



- Knives are adjusted outside of the machine
- Mobile Compact design
- Different rotor types available
- Easy accessibility
- Aggressive tangential infeed



Rotor and stator knives are pre-set outside the machine prior to installation in a supplied fixture. This makes awkward adjustment inside the machine unnecessary.

Applications

The GSE series of machines are designed as economical granulators for use in in-house recycling. The cutting geometry of the GSE 300 series makes it ideal for the grinding of small thin walled hollow parts. The complete GSE granulator line achieves a high quality regrind independent of the material type or form such as injection molding parts, blow molded parts, profiles, sheets, film, etc.



The GSE granulators are available with different rotor options to fit different applications, all rotors feature the V-cut technology creating a high quality regrind.

General Description

For the GSE 300 series different rotor designs are available in widths ranging from 300 mm to 1400 mm with a diameter of 300 mm. The completely welded cutting chamber in conjunction with the "V" type rotor design ensures dependability in operation and universal application use.

The housing design offers easy and quick access to the cutting chamber during rotor and stator knife changes, servicing or screen changes.



The user friendly design of the GSE series granulators allows quick and easy access to the cutting chamber for maintenance and cleaning.

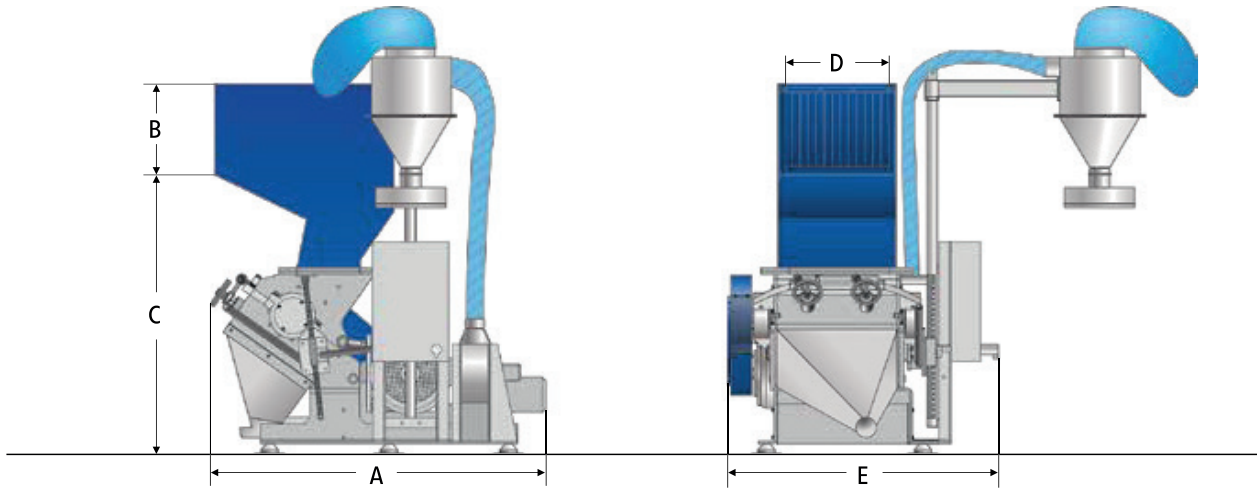

Technical Specifications

Type	300/300	300/600	300/1000
Rotor diameter (mm)	300	300	300
Rotor width (mm)	300	600	1000
Drive capacity (kW)	7.5	18.5	18.5
Rotor knives (rows)	3	3	3
Stator blades (rows)	2	2	2
Screen size (mm)	> 6	> 6	> 6
Effective working area (mm)	400 x 290	400 x 590	400 x 990
Weight approx. (kg)	900	1000	1350

Dimensions

Type	300/300	300/600	300/1000
A (mm)	1760	1810	1370
B (mm)	460	460	460
C (mm)	1420	1420	1420
D (mm)	300	590	990
E (mm)	1085	1350	1540

ZERMA AMERICA

9120 Centerlinks Commerce Dr., Unit 4
 Fort Myers, FL 33912
 239-219-1100
www.zerma-america.com
sales@zerma-america.com

zerma-america.com

