

# GSE 700

## Economical granulators



- Knives are adjusted outside of the machine
- Mobile Compact design
- Different rotor types available
- Easy accessibility
- Aggressive tangential infeed



Rotor and stator knives are pre-set outside the machine prior to installation in a supplied fixture. This makes awkward adjustment inside the machine unnecessary.

### Applications

The GSE series of machines are designed as economical granulators for use as central granulator for in-house recycling. The cutting geometry of the GSE 700 series allows even voluminous materials to be ground. The complete GSE series line achieves a high quality regrind independent of the material type or form such as injection molded parts, blow molded parts, profiles, sheets, film, etc.



The GSE granulators are available with different rotor options to fit different applications, all rotors feature the V-cut technology creating a high quality regrind.

### General Description

For the GSE 700 series different rotor designs are available in widths ranging from 700 mm to 1400 mm with a diameter of 700 mm. The completely welded cutting chamber in conjunction with the "V" type rotor design ensures dependability in operation and universal application use.

The housing design offers easy and quick access to the cutting chamber during rotor and stator knife changes, servicing, or screen changes.



The base of the GSE 700 series makes the machine very sturdy, while maintaining the easy accessibility for maintenance and cleaning.

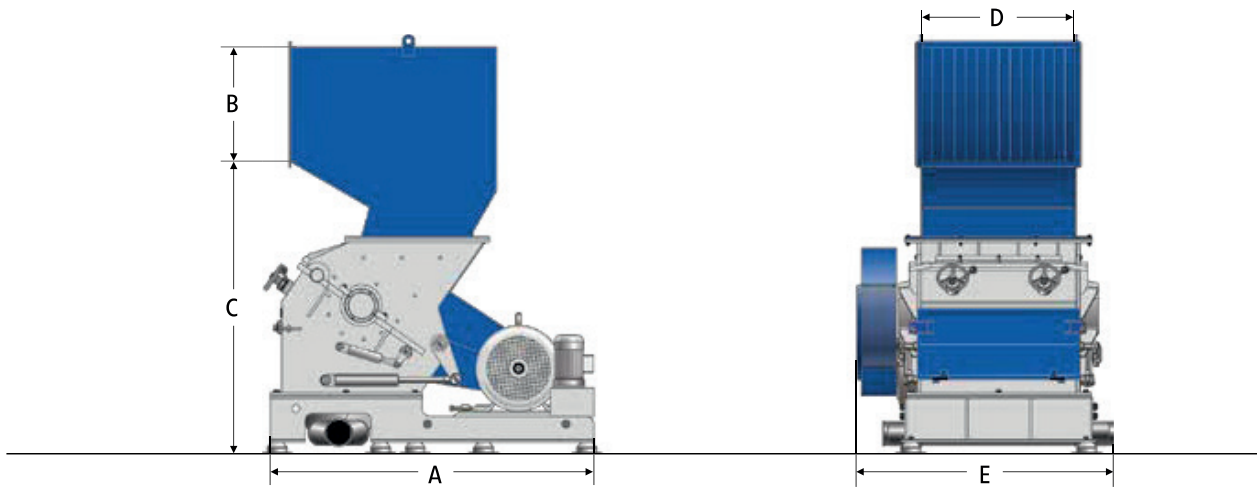

### Technical Specifications

Type	700/700	700/1000	700/1400
Rotor diameter (mm)	700	700	700
Rotor width (mm)	700	1000	1400
Drive capacity (kW)	45	55	55
Rotor knives (rows)	5 or 7	5 or 7	5 or 7
Stator blades (rows)	2 or 3	2 or 3	2 or 3
Screen size (mm)	> 6	> 6	> 6
Effective working area (mm)	720 x 700	720 x 990	720 x 1400
Weight approx. (kg)	2840	3530	4500

### Dimensions

Type	700/700	700/1000	700/1400
A (mm)	2050	2050	2050
B (mm)	780	780	780
C (mm)	2040	2040	2040
D (mm)	715	985	1430
E (mm)	1400	1670	2120

## ZERMA AMERICA

9120 Centerlinks Commerce Dr., Unit 4  
 Fort Myers, FL 33912  
 239-219-1100  
[www.zerma-america.com](http://www.zerma-america.com)  
[sales@zerma-america.com](mailto:sales@zerma-america.com)

[zerma-america.com](http://zerma-america.com)

