



Solutions for Inline Recycling

ZERMA

The Home of Size Reduction



ZERMA offers a suitable solution for any challenge in the field of plastic recycling.

For the inline recycling sector **ZERMA** offers the following machine series:

GSL Slow Speed Granulators to directly grind runners and sprues from the injection machine

GST Soundproofed granulators featuring a very aggressive tangential infeed and cutting chamber

GSC Soundproofed compact granulators suited for a wide variety of inline tasks

GSE Same as GSC series, but without soundproofed housing

All machines offer these benefits:

- Consistent end product
- Reduced fine particles
- Low heat generation
- Reduced noise emission
- Small footprint and easy maintenance

Take control of your scrap

Granulation and size reduction of plastics, e.g. scrap from blow and injection molding or extrusion processes, requires a lot of know how and experience.

ZERMA has a long history in the design and implementation of size reduction equipment and offers a product portfolio which is as wide as the spectrum of materials that need to be processed.

PC/ABS

POM

Inline recycling application examples

GSL slow speed granulator

working next to an injection molding machine, directly grinding runners and rejects. The regrind is directly reintroduced into the production.

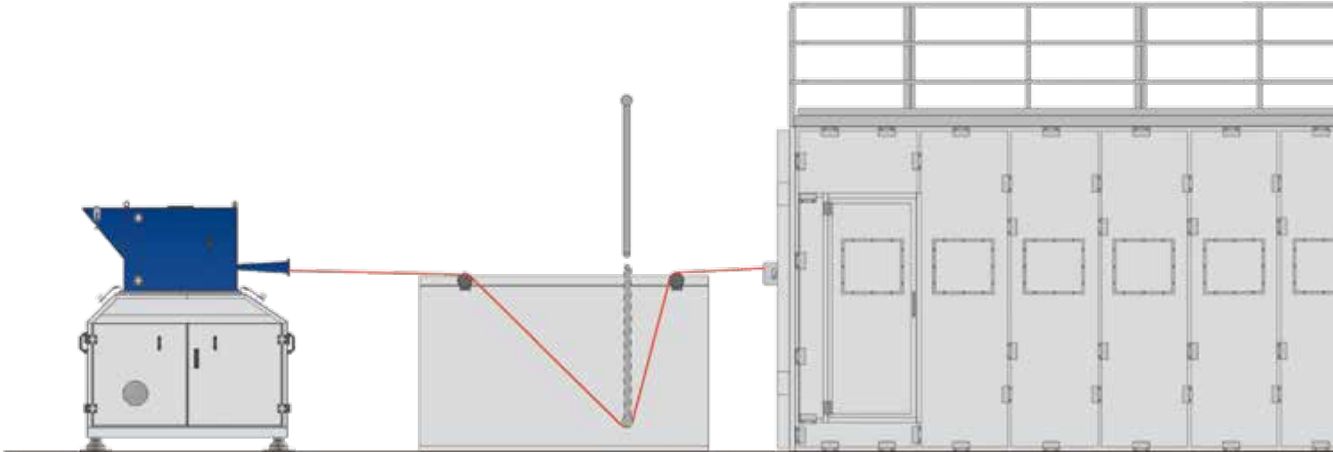
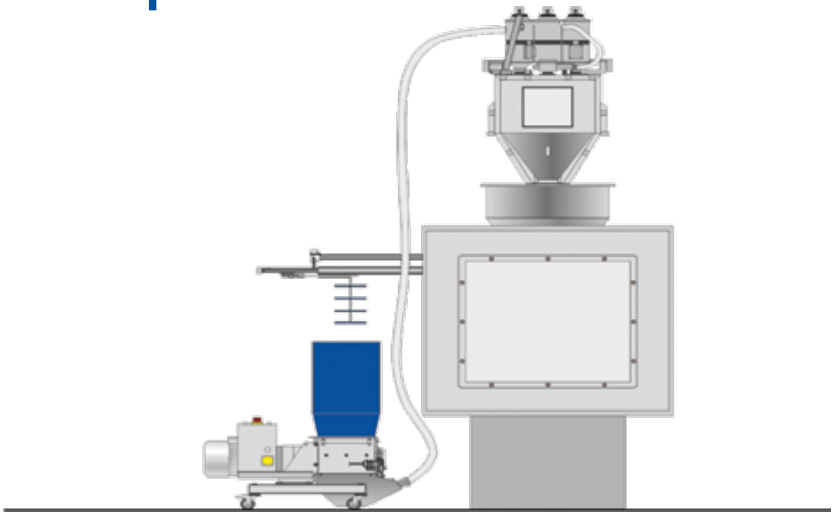

ZERMA granulators can be integrated into a variety of production processes. Common applications include rejects and scrap from injection molding of small parts like caps and closures to TVs or automotive components as well as flush from blow molding applications.

With an optional roller feeder, the machines can be used for the inline processing of edge trim and skeletal waste in extrusion and thermoforming lines. Our skilled and experienced team of engineers will help you integrate a **ZERMA** system into your facility and design a tailored solution.

GST granulator

in a blow molding application. Tops and tails are fed to the granulator by a conveyor and the resulting material is directly fed back into the extruder.

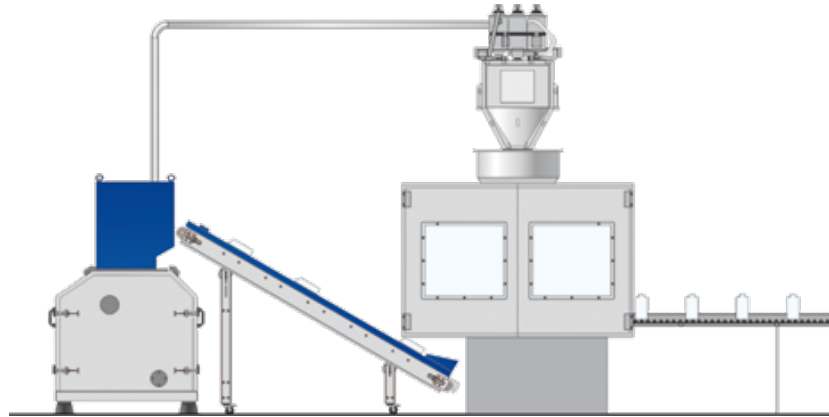

GSC granulator

grinding skeletal waste in a thermoforming process. The machine is equipped with a dual feed hopper in order to accept reject products.

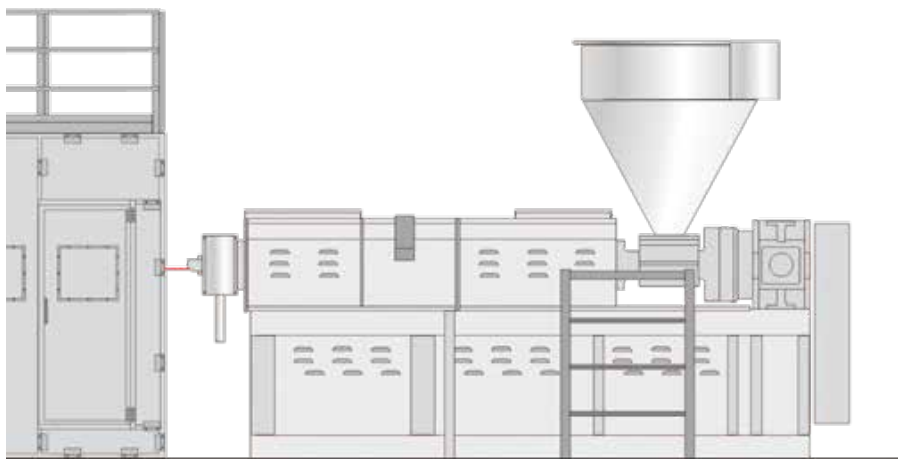

Advanced engineering –
great results

The right machine for today's inline recycling requirements

The **ZERMA** granulators of the GSL, GST and GSC series are designed for the inline recycling of scrap like runners, sprues, tops, tails and reject parts directly at the production machine. The resulting regrind can either be collected in a central silo or be mixed with virgin material and reused immediately. The compact size and low noise of these machines makes them a perfect fit for in-house applications.



GSL

GST

GSL

- Machines can be integrated into the production line
- Low dust and noise emission
- Simple maintenance and up to date safety
- Different cutter and rotor designs to fit specific applications tailored to inline applications



GSC

GSL

ZERMA range of inline granulators

GST series– aggressive tangential infeed

The **ZERMA** granulators of the GST series are available in two rotor diameters, 250 and 400 mm with widths ranging from 300 to 1000 mm. While the smaller machines feature an open F rotor, the bigger machines rely on a heavier S rotor. The rigid design makes them dependable units and includes advanced standard features such as replaceable wear plates.



- Compact design
- Soundproofed chamber and hopper
- Aggressive infeed and curved back wall
- Large screen area
- Knives are adjusted outside the machine

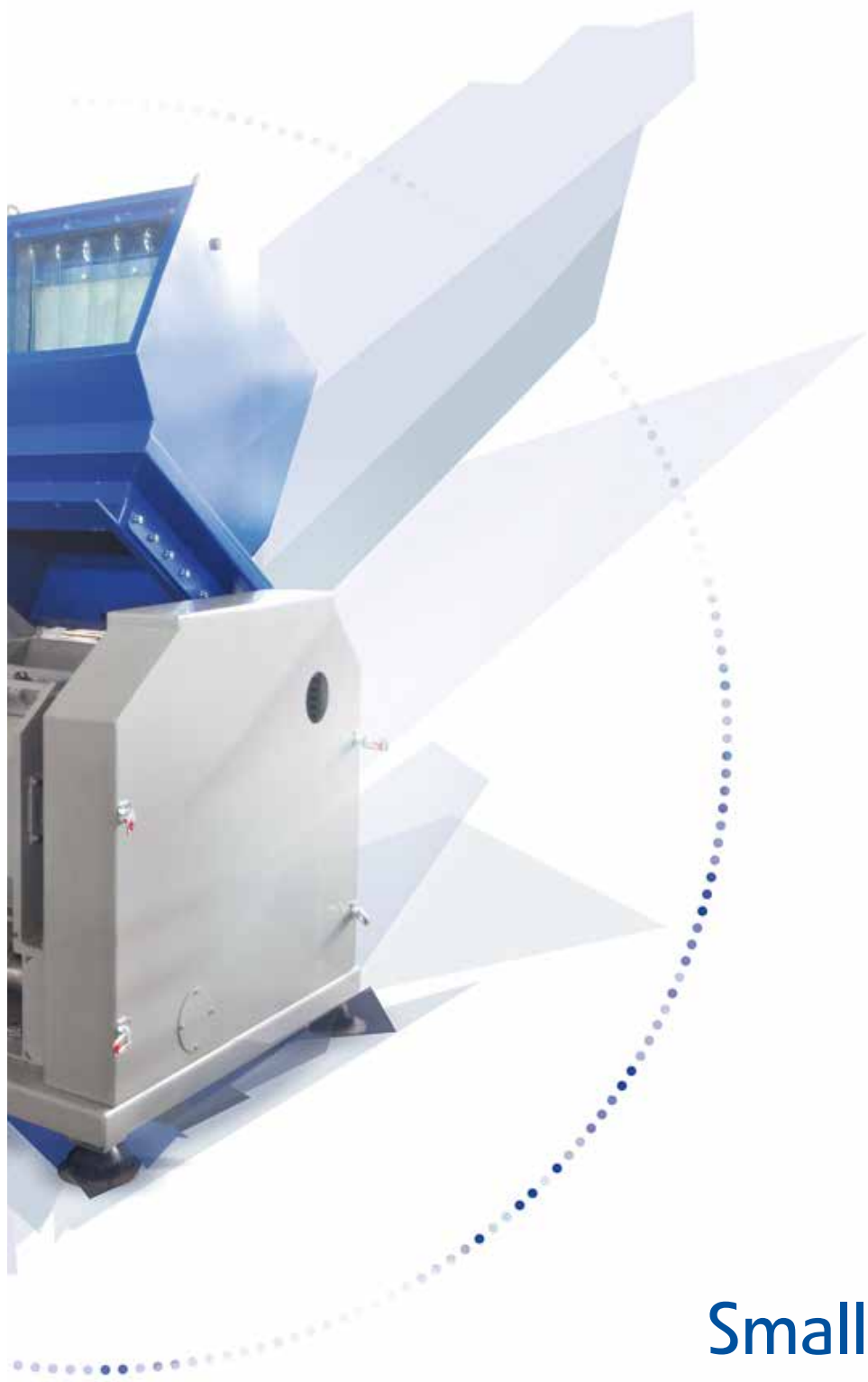

**Small footprint –
great results**

GSC series – the soundproofed all-rounder

The **ZERMA** GSC compact/soundproof granulators are designed with a complete soundproof enclosure resulting in an extremely quiet operation. Different rotor designs are available in widths ranging from 300 to 1400 mm with a diameter ranging from 300 to 700 mm.

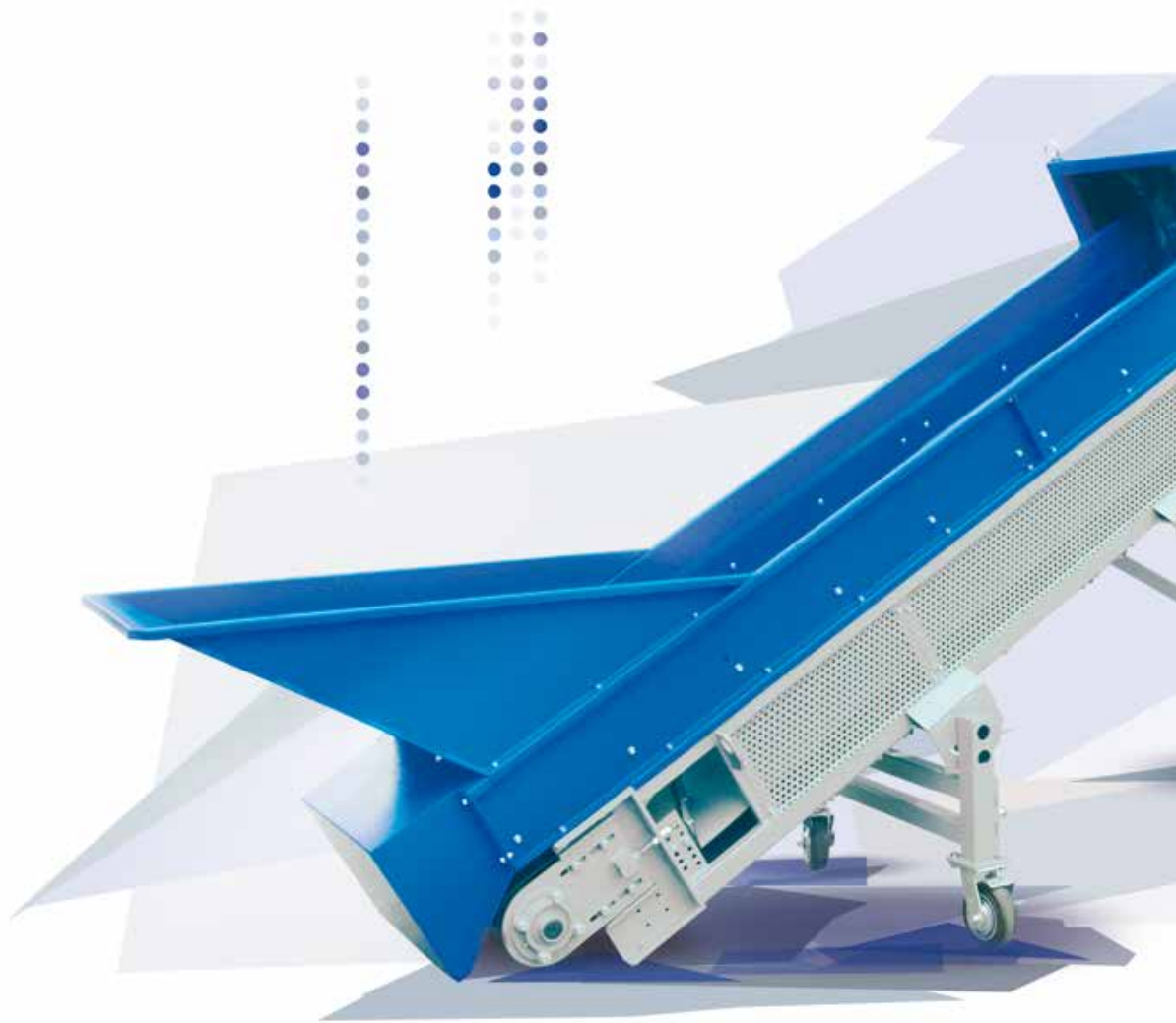

The completely welded cutting chamber in conjunction with the V rotor GSC design ensures dependability in operation and universal application use. While it delivers excellent soundproofing capabilities, it still offers easy and quick access to the cutting chamber during rotor and stator knife changes, servicing, or screen changes.



GSC – with optional feeding conveyor

- Sturdy compact design
- Different rotor types available
- Soundproofed housing
- Knives are adjusted outside of the machine
- Integrated controls

Efficient cut – great results

GSL series – dependable low speed performance

The beside the press granulators of the **ZERMA** GSL series run at low speed to ensure low noise operation and low dust regrind. The specially designed rotor knives can be sharpened numerous times and due to their unique design do not need to be adjusted. The granulators are fed via a sound absorbing hopper which can be tailored to fit your specific needs. All GSL machines offer connections for vacuum systems in order to directly reintroduce the regrind into your production process.



GSL – with optional conveyor belt and integrated metal detector

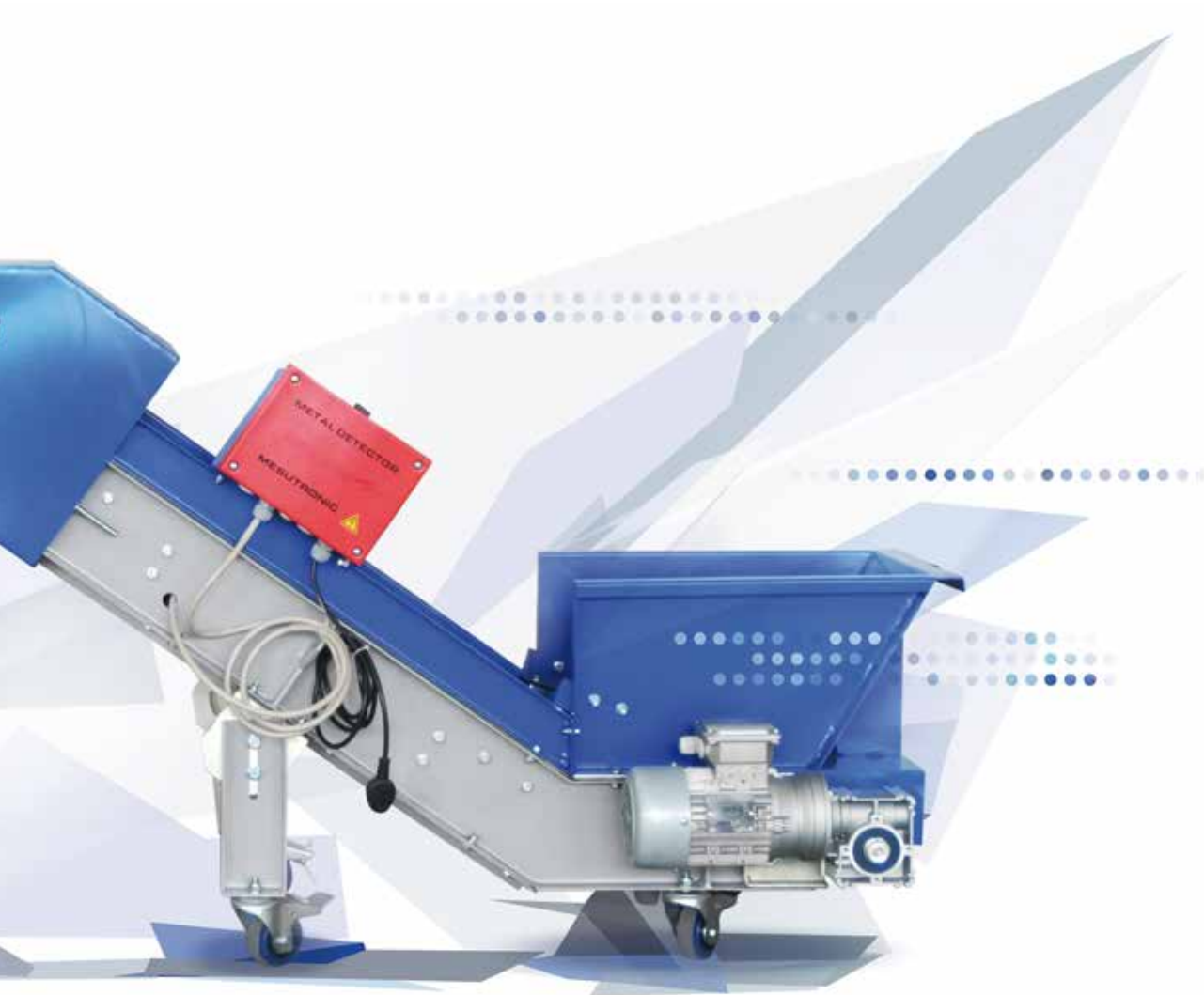

- Direct drive
- Specially designed rotor knives do not need to be adjusted in the machine
- Easy tool-less access to the machine for maintenance and cleaning
- Frame and hopper can be tailored to fit your needs

Low speed – great results

PM series – High Speed Precision Pulverizer

The disc pulverizers of the PM series are available with disc diameter from 300 to 800 mm. These pulverizers are high speed, precision grinders for the processing of medium hard, impact resistant, and friable materials. The material to be pulverized is introduced through the center of a vertically fixed grinding disc which is mounted concentrically with an identical high speed rotating disc. Centrifugal force carries the material through the grinding area and the resulting powder is collected with a blower and cyclone system. Depending on the application the machines can be equipped with one piece grinding discs or grinding segments.



- Simple adjustment of cutting gap
- Choice of discs or segments
- Low drive power - High throughput
- Innovative efficient design
- Wide range of accessories
- Easy temperature control

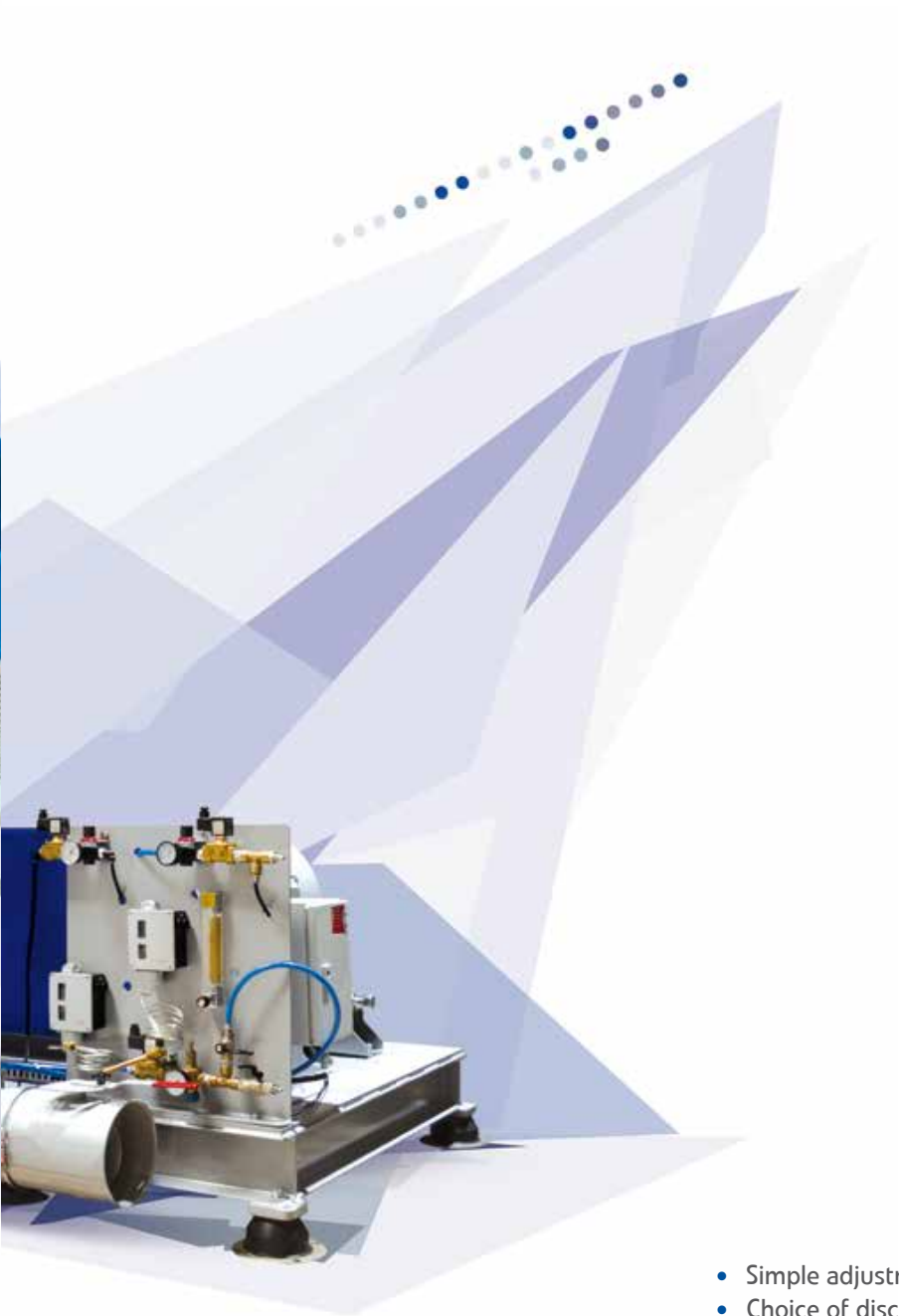

- Simple adjustment of cutting gap
- Choice of discs or segments
- Low drive power - High throughput
- Innovative efficient design
- Wide range of accessories
- Easy temperature control

High speed – great results

Technical details – well thought out and efficient



GSL:

The curvature of the specially profiled rotor knives ensures a constant cutting radius after re-sharpening thus maintaining the original cutting gap.

Awkward knife adjustment is no longer necessary.



GSL:

The Quick Snap System allows the lower front plate section to be easily removed for granulator cleaning. The lower front plate section is held in position by two sturdy lever clamps.



GSL:

Staggered rotor blades create an individual blade cut thus increasing the cutting torque. All of the machines in this series are therefore suitable for grinding more solid materials and thicker walled sprues.



GST, GSC, GSE:

The granulators are available with different rotor options to fit different applications. All rotors feature the V-cut technology creating a high quality regrind.

GST, GSC, GSE, GSL:

All machines are designed according to the latest mechanical and electrical safety requirement.





GST:

The curved back wall of the cutting chamber ensures for aggressive ingestions while also avoiding blockages.



GST, GSC:

In order to keep the machines as compact as possible, the motor and opening system are integrated into the sound dampening enclosure of the machine.



GST, GSC, GSE:

Replaceable wear plates in the cutting chamber ensure a long service life of the granulator even with difficult materials

GST, GSC, GSE: The user friendly design of the granulators allows quick and easy access to the cutting chamber for maintenance and cleaning.



Advanced engineering – great results

Technical details



The ZERMA PM Pulverizers can be equipped with either one piece or segmented grinding discs. Both are made from high quality tool steel and can be treated to withstand wear longer.



The material temperature is monitored in the process, an automated cooling system will ensure the temperature is kept at a defined level.



The material is fed into the Pulverizer by a vibrating dosing channel, the feeding rate is automatically adjusted based on the motor's amperage and material temperature.



One of the main fields of use for the ZERMA PM Pulverizers is the pulverization of PVC regrind in pipe and profile recycling. Working in line with a shredder and granulator to have a balanced and efficient system to handle in house production waste. Another application is the grinding of PE for Rotomolding applications, here the PM Pulverizer is used in the production process to create the powder needed in the process. In this process a screening machine is necessary to ensure the right output size, distribution, and flow properties of the ground material.

Technical specifications – overview

Applies to all models: screen size is >5 mm or > 6 mm and each machine has 2 rows of stator blades
 The model name is composed of the rotor diameter and rotor width (**A/B**)

- A** = Rotor diameter in mm
- B** = Rotor width in mm
- C** = Drive capacity in kW
- D** = Rotor knives in pcs
- ExF** = Feed opening in mm x mm

- All dimensions are in mm
- G** = length
 - H** = height
 - I** = width

GSL Series

A/B	150/150	150/250	150/350	180/120	180/180	180/300	180/430	300/400	300/600	300/800
C	1.5	2.2	3	2,2	3	4	4	7.5	11	18.5
D	15	27	36	12	18	30	45	33	48	66
ExF	513x336	513x439	513x535	345x345	345x345	345x345	430x290	405x400	600x400	830x400

G	974	974	974	835	890	1095	1240	1125	1125	1135
H	1162	1162	1162	1070	1070	1070	1360	1735	1735	1740
I	423	519	616	455	455	455	615	1035	1230	1635

GSL 150

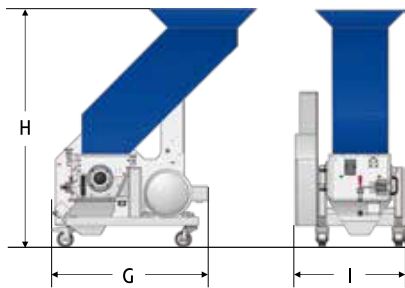

GSL 180

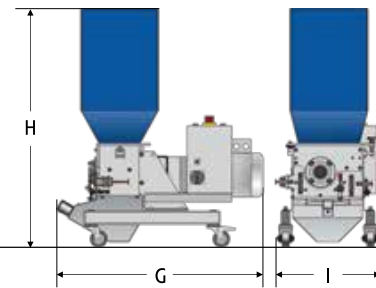

GSL 300

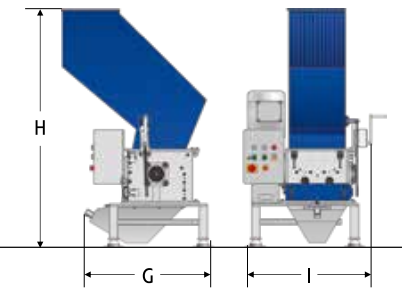

Wide range – great results

Technical specifications – overview

GSC Series

A/B	300/300	300/600	300/1000	500/500	500/700	500/1000	500/1400	700/700	700/1000	700/1400
C	7,5	18,5	18,5	30	37	45	45	45	55	55
D	3x2	3x2	3x2	3 or 5x2	3 or 5x2	3 or 5x2	3 or 5x2	5 or 7x2	5 or 7x2	5 or 7x2
ExF	300x420	590x420	990x420	500x600	700x600	990x540	1400x540	700x740	990x740	1400x740

G	1550	1550	1550	2010	2010	2410	2410	2560	2560	2560
H	1990	1990	1990	2395	2395	2565	2580	2880	2880	2980
I	1360	1680	1950	1380	1580	1880	2210	1560	1850	2210

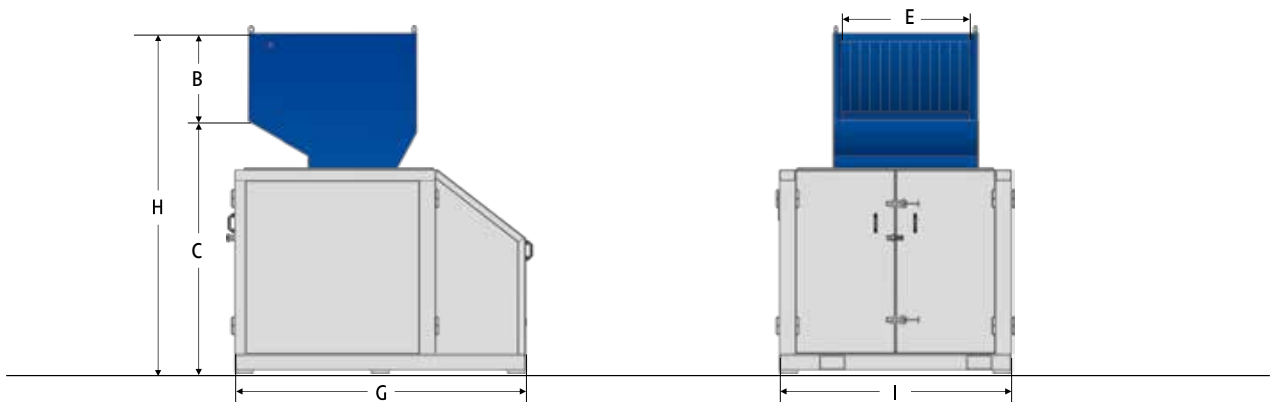

GST Series

A/B	250/300	250/450	250/600	400/600	400/1000
C	7.5	11	18.5	22	30
D	3x1	3x1	3x2	3x2	3x2
ExF	300x370	450x370	600x370	590x490	990x490
G	1350	1600	1750	1550	1950
H	1880	1880	1880	2180	2180
I	1220	1220	1220	1460	1460

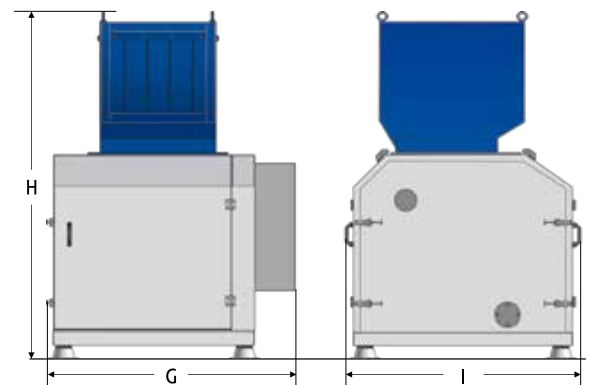

GSE Series

A/B	300/300	300/600	300/1000	500/500	500/700	500/1000	500/1400	700/700	700/1000	700/1400
C	7.5	18.5	18.5	30	37	45	45	45	55	55
D	3x2	3x2	3x2	3 or 5x2	3 or 5x2	3 or 5x2	3 or 5x4	5 or 7x2	5 or 7x2	5 or 7x4
ExF	300x460	590x460	990x460	515x580	715x580	985x580	1430x580	715x780	985x780	1430x780

G	1760	1810	1370	1675	1675	1900	1900	2050	2050	2050
H	1880	1880	1880	2420	2420	2420	2420	2820	2820	2920
I	1085	1350	1540	1130	1330	1645	2120	1400	1670	2120

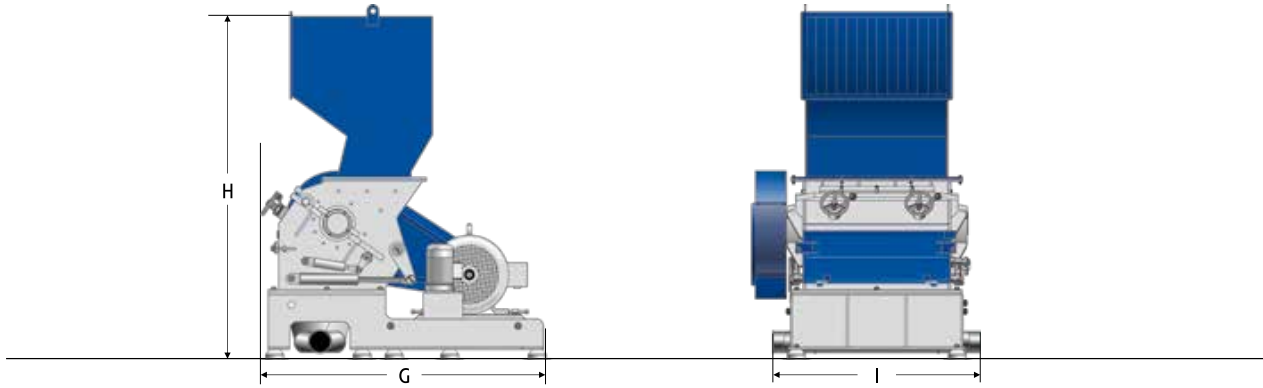

PM Series

The model name is composed of the discs diameter (A)

- All dimensions are in mm
- A** = Discs diameter in mm
 - B** = Drive capacity in kW
 - C** = Weight in approx. kg
 - D** = Throughput in approx kg/h
 - G** = length
 - H** = height
 - I** = width

A	300	500	800
B	22	55	90
C	900	1800	2500
D	50-250	100-500	200-800
G	1365	1800	2085
H	1830	2110	2440
I	1515	1840	1680

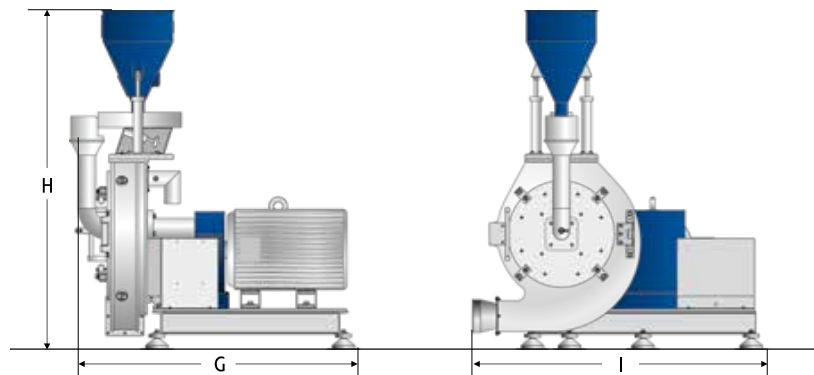

Wide range – great results

The product range – the right solution for any application



GSE - Economical granulators

GSH - Heavy duty granulators

ZSS/ZPS - Generalpurpose shredders

With more than 70 years of experience, **ZERMA** is one of the leading manufacturers of high quality size reduction machinery. With the wide range of machines **ZERMA** covers the whole spectrum of plastic size reduction applications.



ZXS - Heavy duty shredders

ZERMA – The Home of Size Reduction



The Home of Size Reduction

zerma-america.com

ZERMA AMERICA

9120 Centerlinks Commerce Dr., Unit 4
Fort Myers, FL 33912

239-219-1100

www.zerma-america.com
sales@zerma-america.com