

GST

Compact granulator

- Compact design
- Soundproofed chamber and hopper
- Aggressive infeed and curved backwall
- Large screen area
- Knives are adjusted outside the machine



The GST granulators are designed for the inline recycling of voluminous parts such as bottles and canisters in blow molding applications.



The tangential cutting chamber paired with the aggressive open rotor design ensures reliable ingestion of voluminous parts. The curved cutting chamber backwall reduces the risk of parts getting stuck.

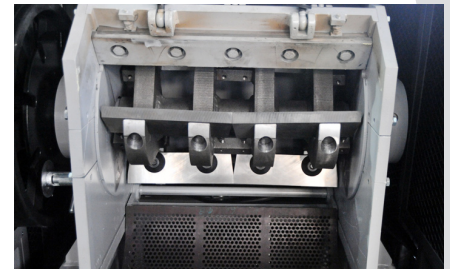

The cutting chamber sits in a soundproofed enclosure to ensure quiet inline operation. The rotor and screen area are easily accessible for cleaning and maintenance without the need for additional tools.

General Description

All machines in the GST series feature a compact soundproofed enclosure and sound dampening hoppers. The granulators are available in two rotor diameters, 250 and 400 mm with widths ranging from 300 to 1000 mm. While the smaller machines feature an open F rotor, the bigger machines rely on a heavier S rotor. The curved backwall of the cutting chamber ensures an aggressive ingestion while also avoiding blockages. The rigid design makes them dependable units and includes advanced standard features such as replaceable wear plates. As on all ZERMA granulators, the rotor and stator knives are adjusted outside the machine to reduce downtime for maintenance.

Applications

The compact inline granulators of the GST series are primarily designed for use in blow molding applications to recycle voluminous parts such as bottles, canisters, crates, as well as blow molding flush and injection sprues. The low feeding height makes them suitable for both hand and conveyor feeding of these parts. The low noise level and small footprint makes them the perfect fit for inline recycling operations.



The Home of Size Reduction

GST

Compact Granulator

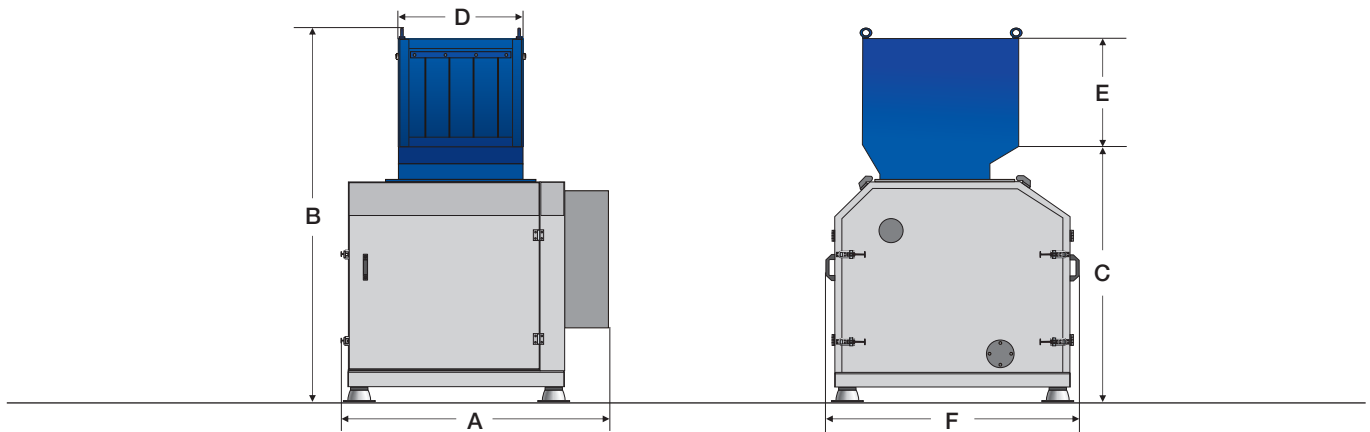

Technical Specifications and Dimensions

Model	250/300	250/450	250/600	400/600	400/1000
Rotor diameter (mm)	250	250	250	400	400
Rotor width (mm)	300	450	600	600	1000
Drive capacity (kW)	7.5	11	18.5	22	30
Rotor knife (rows)	3 x 1	3 x 1	3 x 2	3 x 2	3 x 2
Stator blades (rows)	2	2	2	2	2
Screen size (mm)	≥6	≥6	≥6	≥6	≥6
Effective working area (mm)	250 x 300	250 x 450	250 x 600	400 x 600	400 x 1000
Weight approx (kg)	1200	1400	1850	3300	4200
A (mm)	1350	1600	1750	1750	1950
B (mm)	1880	1880	1880	2180	2180
C (mm)	1380	1380	1380	1540	1540
D (mm)	300	450	600	590	990
E (mm)	370	370	370	490	490
F (mm)	1220	1220	1220	1460	1460

ZERMA

311 Era Drive
 Northbrook, IL 60062
 Phone: 1-847-291-1300
sales@zerma-america.com

zerma.com

