

# ZCS

## Shredder / Granulator Combination

- Compact space saving design
- Low noise emission
- Versatile size reduction concept
- Flexible discharge options

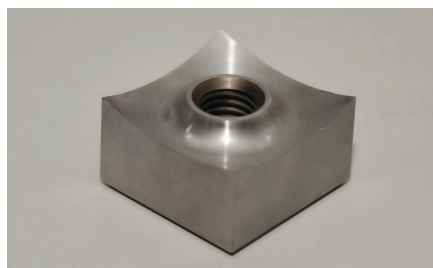

The ZCS machines rely on the proven E type rotor from the ZSS shredders with bolted knives and knife holders.



The granulator part uses a sturdy F+ rotor to ensure a good ingestion of the material flow while still being able to handle thicker and heavier particles.

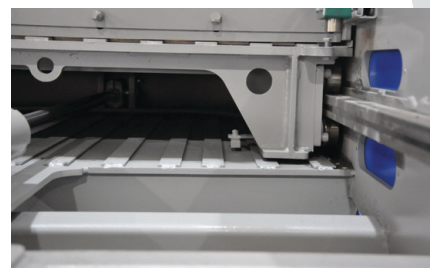

The ZCS system uses a sturdy roller guided drawer type ram to feed the material into the shredder. Segmented cutting chamber and ram allow trouble free processing of thin materials.

### General Description

The ZCS size reduction system combines a shredder with a granulator in a single-spacing system for the processing of production waste.

The shredder part is equipped with a 400mm diameter E rotor using ZERMA's proven knife and knife holder design, driven by a high-torque gear drive, which in comparison to a direct drive also handles tougher input materials well. The large material hopper and the powerful horizontal pusher allow processing of voluminous as well as heavier parts. The lower part of the system consists of a 3-blade granulator rotor based on the GST series. The shredder and granulator are matched to work together ideally and in conjunction with an advanced control system ensure smooth reliable operation.

### Applications

The ZCS system has been designed mainly for in-house use in blow and injection molding applications, yet it can be adopted in other fields too. The small foot print allows the system to be integrated into existing factory workshops easily. Being a closed system also reduces the risk of contamination compared to using a conveyor belt in a traditional two stage recycling system. The system is well suited for large volume parts and thicker materials such as flush or purging.



**The Home of Size Reduction**

# ZCS

## Shredder / Granulator Combination

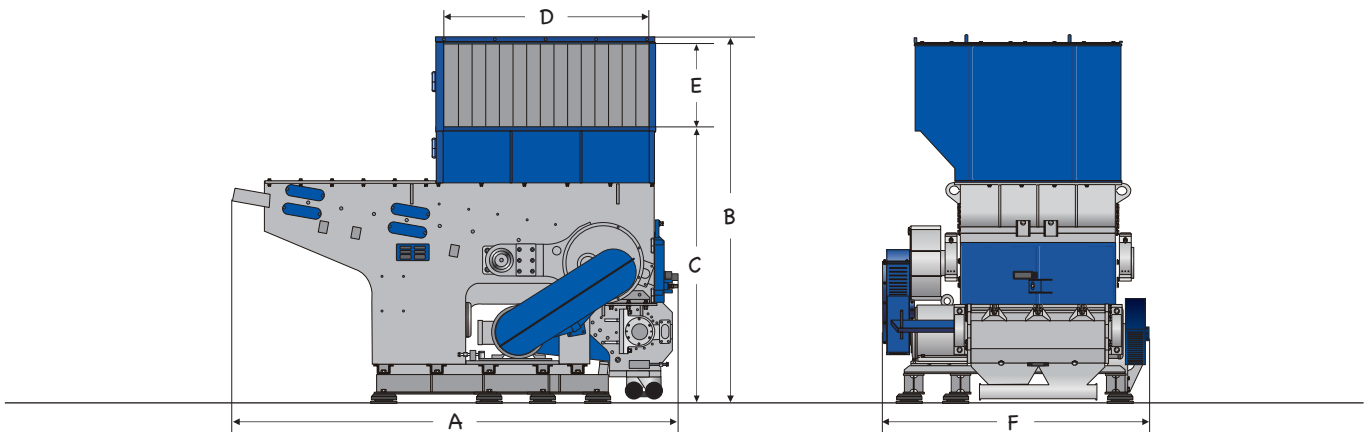

### Technical Specifications and Dimensions

#### Model

	600	1000	1400
Feed opening	570 x 490	1500 x 600	1880 x 1000
Rotor width	570 mm	1000 mm	1400 mm
Rotor diameter (Shredder)	310 mm	400 mm	400 mm
Drive capacity (Shredder)	11 kW	30 kW	45 kW
Hydraulic drive capacity (Shredder)	0.75 kW	3.75 kW	3.75 kW
Rotor knives (Shredder)	26	27	34
Stator knives (Shredder)	1 x 2	1 x 4	1 x 5
Rotor diameter (Granulator)	300 mm	300 mm	350 mm
Motor capacity (Granulator)	7.5 kW	15 kW	22 kW
Rotor knives (Granulator)	3 x 2	3 x 2	3 x 2
Stator knives (Granulator)	2 x 1	2 x 1	2 x 1
A (mm)	1960	3348	4250
B (mm)	2370	2750	3410
C (mm)	1840	2080	2355
D (mm)	570	1538	1880
E (mm)	490	600	1000
F (mm)	1550~2540	1990	2500

#### ZERMA

311 Era Drive

Northbrook IL 60062

847-291-1300 - Sales@Zerma-america.com

Technical modifications reserved / ver1.7 - 04.2018 / en

zerma.com

