

GSC 300

Compact sound-proofed granulators



- Knives are adjusted outside of the machine
- Compact design
- Different rotor types available
- Soundproofed housing
- Aggressive tangential infeed



Rotor and stator knives are pre-set outside the machine prior to installation in a supplied fixture. This makes awkward adjustment inside the machine unnecessary.

Applications

The cutting geometry of the GSC series allows even voluminous materials to be ground. The complete GSC series line achieves a high quality regrind independent of the material type or form such as injection molded parts, blow molded parts, profiles, sheets, film, etc. The 300 series GSC machines are mainly used in inline operations for processing of rejected products, or runners and sprues. The small footprint and easy movability make the machines very easy to place in existing operations.



The GSC granulators are available with different rotor options to fit different applications, all rotors feature the V-cut technology creating a high quality regrind.

General Description

The GSC compact/sound proof granulators are designed with a complete sound proof enclosure resulting in an extremely quiet operation. Different rotor designs are available in widths ranging from 300 mm to 1400 mm with a diameter of 300 mm. The completely welded cutting chamber in conjunction with the "V" type rotor design ensures dependability in operation and universal application use. While it delivers excellent sound proofing capabilities, it still offers easy and quick access to the cutting chamber during rotor and stator knife changes, servicing, or screen changes. The sound dampening material used in these machines is based on the latest technological research.



To minimize the needed floor space and make the machine easy to move, machine controls and electrical cabinet are integrated into the machines soundproof housing.

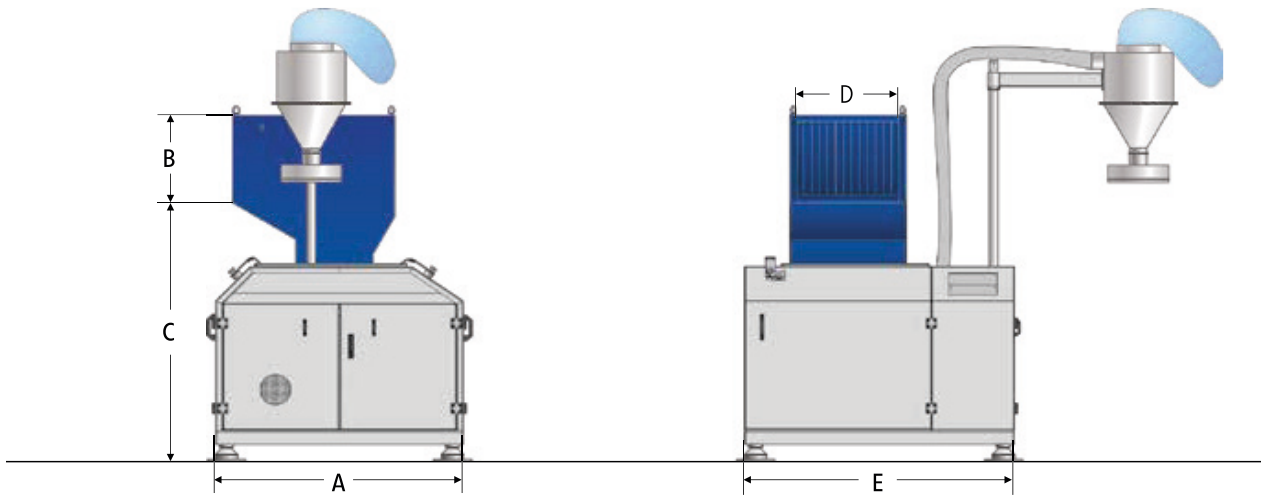

Technical Specifications

Type	300/300	300/600	300/1000
Rotor diameter (mm)	300	300	300
Rotor width (mm)	300	600	1000
Drive capacity (kW)	7.5	18.5	18.5
Rotor knives (rows)	3	3	3
Stator blades (rows)	2	2	2
Screen size (mm)	> 6	> 6	> 6
Effective working area (mm)	400 x 290	400 x 590	400 x 990
Weight approx. (kg)	1200	1400	1850

Dimensions

Type	300/300	300/600	300/1000
A (mm)	1550	1550	1550
B (mm)	420	420	420
C (mm)	1570	1570	1570
D (mm)	300	590	990
E (mm)	1300	1600	1900

