



Granulators

GST · GSC · GSE · GSP · GSH

ZERMA

The Home of Size Reduction

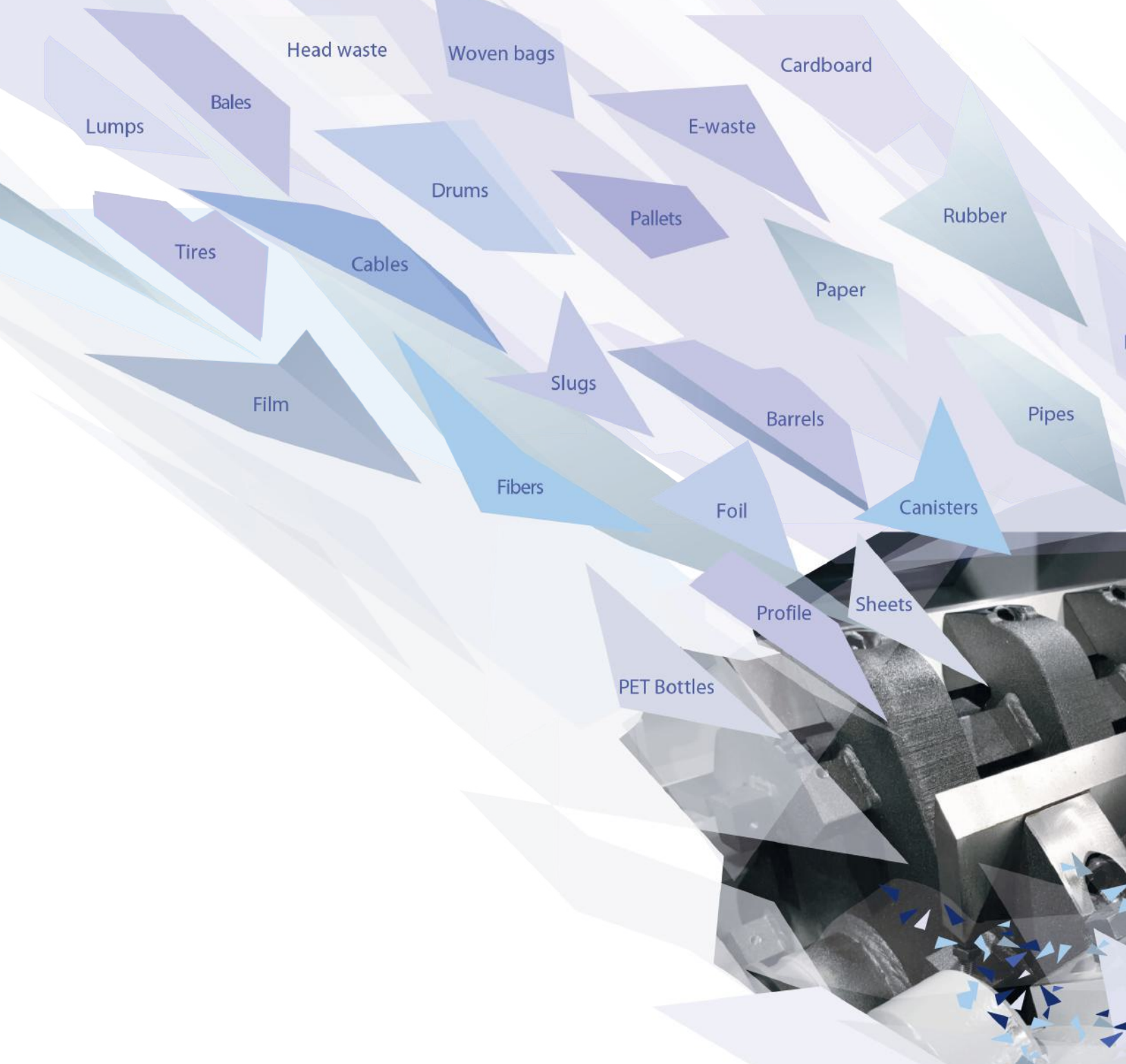

ZERMA granulators are sturdy machines built for the ever changing demands of modern recycling operations. They can be adapted to process a wide variety of materials.

All machines offer these benefits:

- Consistent end product
- Reduced fine particles
- Low heat generation
- Reduced noise emission
- Small footprint and easy maintenance

The Home of Size Reduction

ZERMA is a leading supplier to the plastics industry. With a strong focus on post-consumer and postindustrial recycling the granulators can be adapted to various requirements. They can be customized to withstand high levels of contamination or integrated into washing lines. In combination with **ZERMA** single shaft shredders and accessories we can custom build size reduction systems for high capacities and challenging materials.

ZERMA Granulators - A cut above

Purgings

Scrap



Typical applications of granulators

ZERMA granulators are designed to be dependable sturdy machines in high throughput or demanding applications. They can be used as single stage central granulators for large in house scrap as well as post-consumer and postindustrial recycling. In combination with a **ZERMA** ZSS/ZPS or ZXS single shaft shredder these granulators will ensure constant high through-put with minimal downtime.

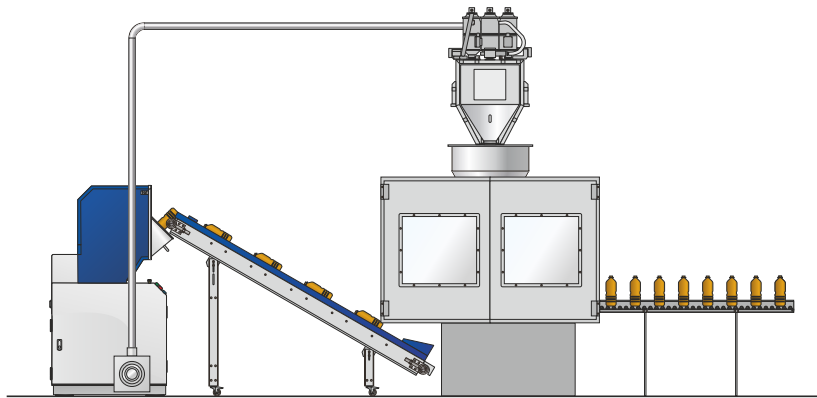

GST granulator

In blow molding applications tops and tails as well as reject products. Tops and tails are fed to the granulator by a conveyor and the resulting material is directly fed back into the process.

GSH granulator placed in a pit for easier floor level feeding of long lengths of pipe.

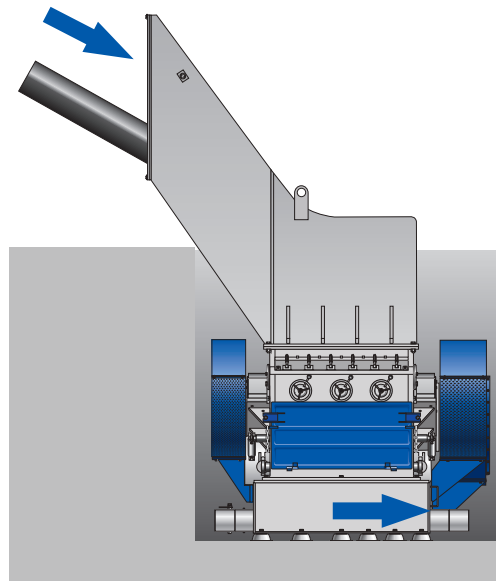

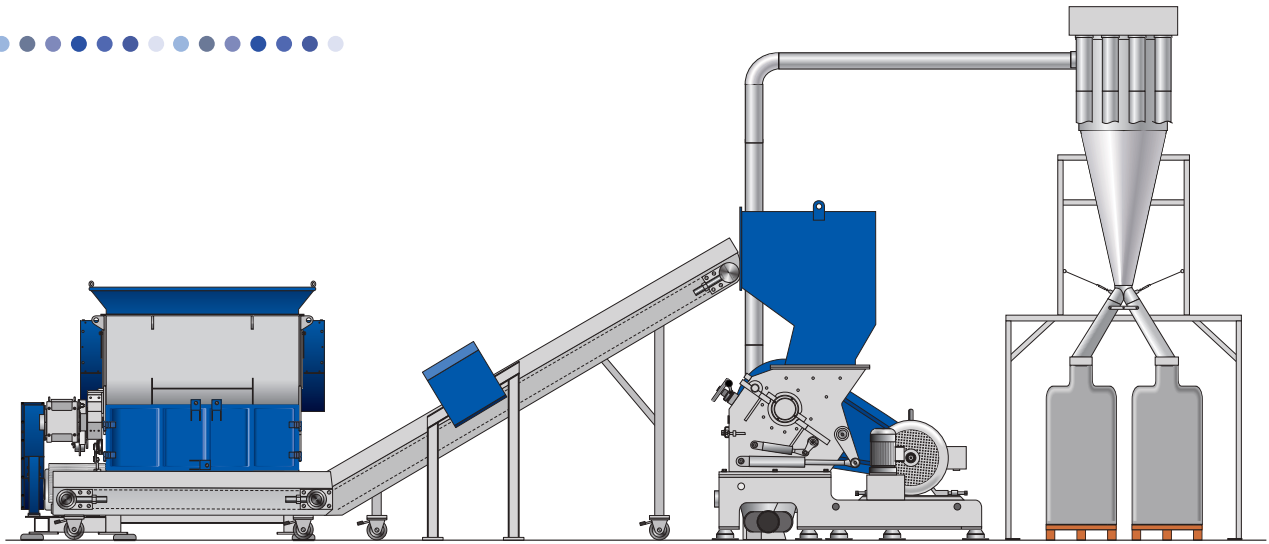

Two stage size reduction system consisting of **ZERMA** single shaft shredder and GSE granulator.

GSH granulator used for in-house grinding of rejected parts and scrap. Machine in fully soundproofed cabin with fine separation system and central filter.

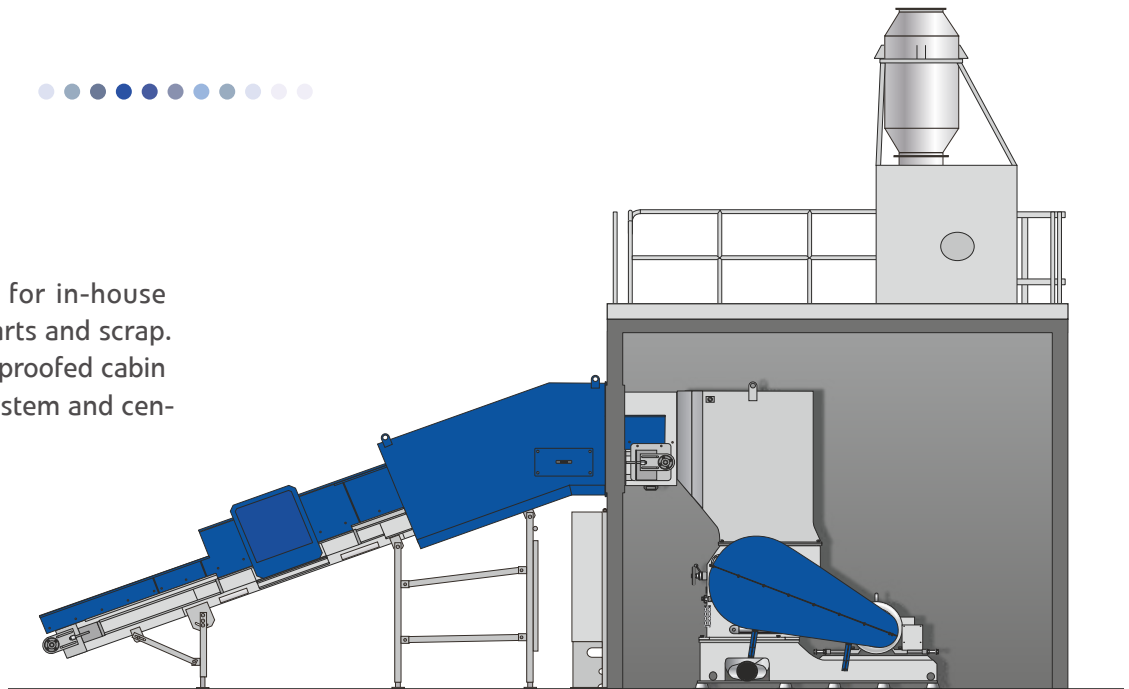

A solution for every application

The right machine for today's recycling requirements

ZERMA offers a comprehensive range of granulators. The GST, and GSC series are specifically designed for recycling in-house scrap such as runners, sprues, tops, tails, and reject parts directly at the production machine.

The resulting regrind can be conveniently collected in a central silo or mixed with virgin material for immediate reuse. These machines, known for their compact size and low noise levels, are an ideal solution for in-house applications.



- Sturdy, Recycling-Focused Design
- Variety of rotor options to adapt to your application
- Easy access for maintenance, service and knife change
- Replaceable wear parts ensure a long operational life
- Seamless Integration with other ZERMA products or into existing infrastructure
- Minimized dust and noise emissions
- Up to date controls and safety

Additionally, **ZERMA** offers the GSE and GSH granulator series to be used as central granulators or as secondary machines after a shredder. They are available in a wide spectrum of sizes ranging from 300 to 1100 mm in diameter and 300 to 2400 mm in width.

Engineered for constant high-quality results, these granulators ensure minimal downtime for service and maintenance, providing a versatile and efficient solution across various applications.



GSE

GSP

ZERMA range of granulators

GST series – aggressive tangential infeed

The **ZERMA** granulators of the GST series are available in two rotor diameters, 250 and 400 mm, with widths ranging from 300 to 1000 mm. While the smaller machines feature an open F rotor, the larger machines utilize a heavier S rotor. These series are designed as quiet, compact units to perfectly fit into blow molding applications. The built-in blower system and control cabinet help to minimize the machine's footprint.





Tool-less access to the machines makes them easy to service and clean, enhancing maintenance efficiency.

The aggressive tangential cutting chamber, combined with the rotor design, ensures optimal ingestion of voluminous containers, while also being robust enough to handle tops and tails in blow molding applications.

Optional belt conveyors, as well as power-saving and current monitoring devices, are available to tailor and integrate the machine into existing setups, offering customization to meet specific operational needs.

Small footprint – great results

GSE series – general purpose granulators

The **ZERMA** GSE series granulators are economical solutions tailored for medium-volume central granulator applications, showcasing versatility that allows them to efficiently process a wide array of materials. This series covers a wide range of sizes with rotor diameters ranging from 300 to 700 mm and widths from 300 to 1400 mm. The completely welded cutting chamber, in combination with the „V“ type rotor design, not only ensures the machines' reliability and durability in operation but also broadens their applicability across various recycling scenarios.





Designed to facilitate ease of maintenance and operational efficiency, the housing of the GSE series granulators provides quick and straightforward access to the cutting chamber. This design consideration is particularly beneficial for tasks such as rotor and stator knife changes, servicing, or screen replacements. The cutting geometry of the GSE series ensures a high-quality regrind regardless of the material type—be it injection molded parts, blow molded parts, profiles, sheets, film, and more. This universal application use, coupled with their dependability, makes the GSE series an ideal choice for businesses seeking to optimize their recycling processes.

The allrounder – for best results

GSC series – the soundproofed all-rounder

The **ZERMA** compact/soundproof granulators are designed with a complete soundproof enclosure, resulting in a quieter operating environment. This series encompasses a wide range of sizes, with rotor diameters ranging from 300 to 700 mm and widths from 300 to 1400 mm. Various rotor designs are available to suit different needs. The fully welded cutting chamber, in conjunction with the V rotor design, ensures dependability in operation and universal application use. While it delivers excellent soundproofing capabilities, it still offers easy and quick access to the cutting chamber for rotor and stator knife changes, cleaning, servicing, or screen changes.



GSC – with optional feeding conveyor



The GSC series machines are mostly used for processing in-house scrap in injection or blow molding applications, but they can be tailored to other applications such as extrusion or thermoforming with the help of optional roller feeders. A whole range of **ZERMA** conveyor belts can be fitted to the machines as well. The use of sound-insulating tunnels further reduces the sound level, enhancing the working environment.

Efficient cut – best final material

GSP series – Pipe- / profile granulators

The **ZERMA** GSP series granulators are specifically engineered for the efficient granulation of long lengths of pipes and profiles. The machines feature rotor widths of up to 1400 mm and diameters ranging from 560 to 700 mm. These granulators are designed with a heavy steel cutting chamber that is completely welded, angled, and equipped with an extended hopper to facilitate easy feeding of long items. The standard V-cut technology ensures a high-quality regrind with a very low percentage of fines, thereby enhancing the quality of the output material. Additionally, the series includes features such as a hydraulically opened hopper and outboard bearings, significantly reducing the risk of contamination and ensuring durability.



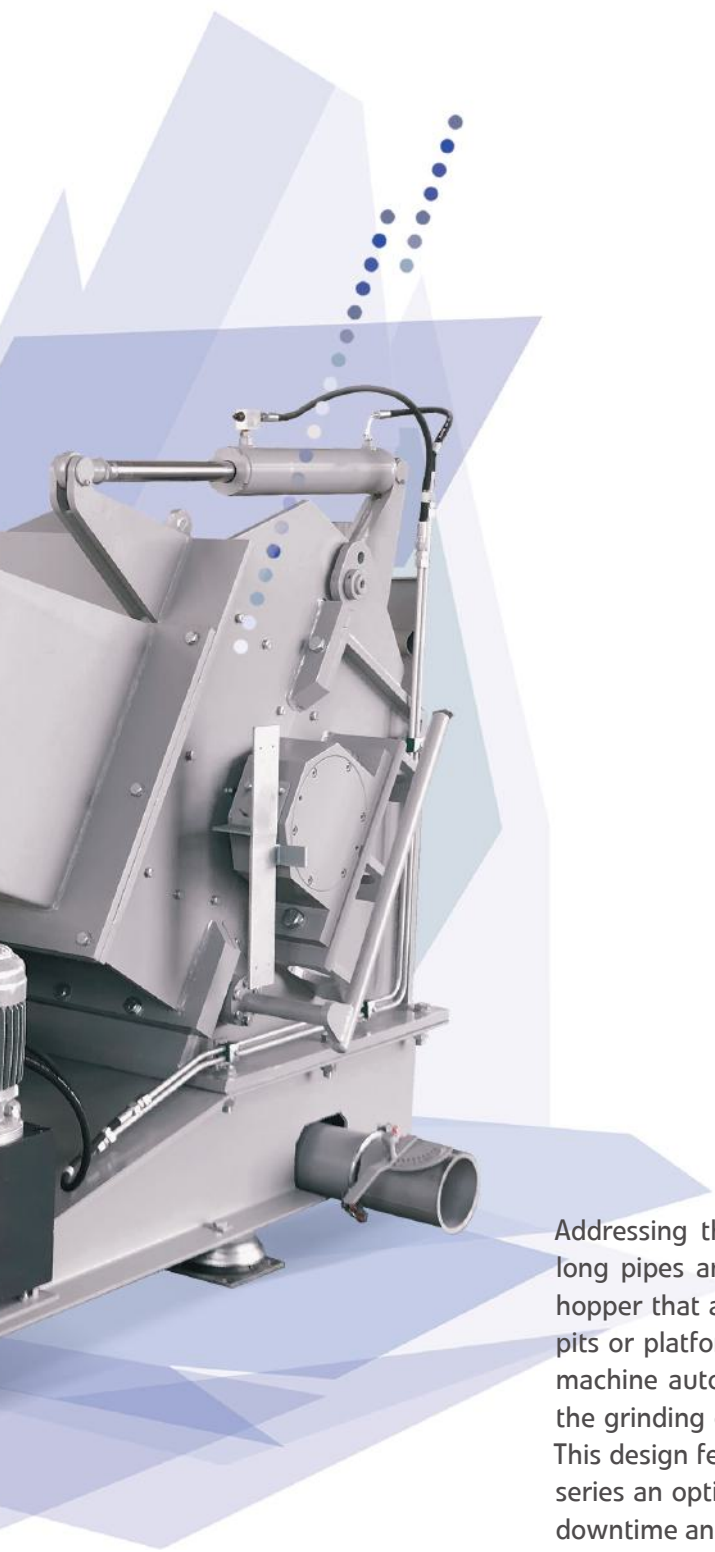

Addressing the challenges posed by conventional granulators in handling long pipes and profiles, the GSP series introduces an almost level feeding hopper that allows for the easy feeding of long pieces without the need for pits or platforms. This innovative design eliminates the risk of blocking; the machine automatically stops accepting material in case of congestion until the grinding chamber is cleared, after which it resumes operation smoothly. This design feature ensures continuous, efficient processing, making the GSP series an optimal solution for recycling long pipes and profiles with minimal downtime and maximum output quality.

Specialized solution – great results

GSH series – the allrounder

The **ZERMA** GSH Heavy-Duty granulator series offers a comprehensive range of machines designed for high-efficiency plastic recycling. Capable of handling everything from in-house recycling of thick-walled parts to high-throughput applications, either as a central granulator or after a shredder, this series is versatile and robust.

The series starts with the GSH 350 and 500 models, featuring rotor widths of 500 to 1000 mm and, making them ideal for central granulating tasks. The mid-range GSH 600 and 700 models are designed for processing materials such as thick-walled pipes and injected parts, with rotor widths from 800 to 1600 mm. The top-tier GSH 800 and 1100 models, engineered for the most demanding tasks, boast rotors up to 2400 mm wide and are capable of outputs exceeding 5 tons per hour.





Across the board, these granulators provide versatility in rotor and hopper designs to ensure optimal performance for a broad spectrum of applications, including secondary grinding post-shredding to achieve higher throughput rates. Additionally, replaceable wear parts and specialized wear-resistant steel protection for the rotor and cutting chamber are available for processing contaminated materials. This ensures longevity and consistent high-quality regrind, making the GSH series an ideal solution for a wide range of recycling challenges.

Advanced cutting – strong performance

Technical details – well thought out and efficient



Wear plates:

Most **ZERMA** granulator series offer replaceable wear plates in the cutting chamber ensuring a long service life even with contaminated or filled materials.

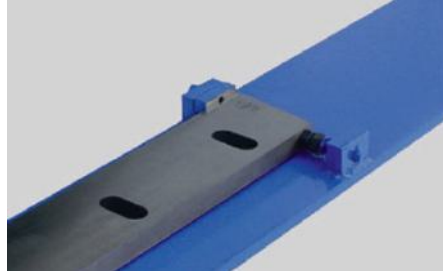

Knife adjustment

Rotor and stator knives are preset outside the machine prior to installation in a supplied fixture. This makes awkward adjustment inside the machine unnecessary.



Specialized hoppers

Most machines can be tailored to specific applications by using specialized hoppers



Cutting chamber

The heavy duty bearings are separated from the cutting chamber to avoid lubricants from entering the cutting chamber and failure of the bearings due to material contamination.





All **ZERMA** granulators are easy to maintain and service. On the larger machines, the front screen access door can be used as a platform to ease access to the rotor during knife changes.



Safety requirement

All machines are designed according to the latest mechanical and electrical safety requirement.



ZERMA granulators feature control and operation panels that meet all safety standards and can be customized to fit specific needs. They also offer seamless integration with peripheral devices like feed conveyors, metal detectors, and unloading systems. Plus, they come with optional intelligent energy-saving functions for improved efficiency, reducing power consumption during idle times and enabling automatic start/stop based on upstream equipment status.

Advanced engineering – great results

Rotor and cutting chamber – details ensure consistent results

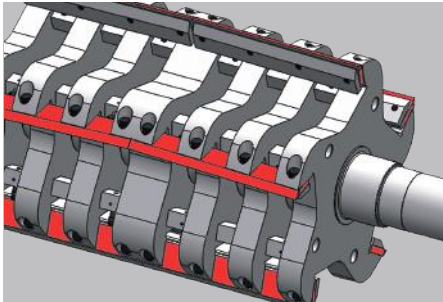

S5-Rotor

This rotor is ideal for light materials as well as thick, rigid pieces such as tanks or crates. Its semi-closed design mitigates the rotor's aggressiveness, providing a balanced approach to material processing.

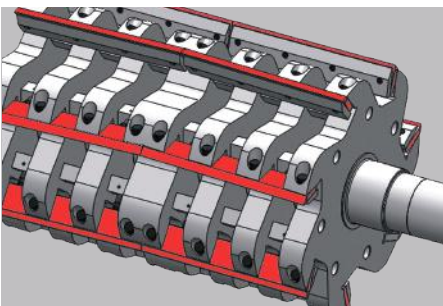
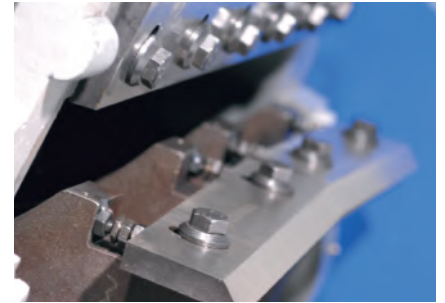

S7-Rotor

The S7 rotor, featuring a closed 7-blade design, is tailored for heavy, thick-walled products. Its less aggressive nature prevents overloading, making it suitable for processing solid lumps or thick-walled pipes without compromising efficiency.

F3-Rotor

The F3 rotor, with knives mounted on the outer part of the rotor, exhibits a more aggressive behavior. This feature renders it exceptionally suitable for processing light and bulky materials, ensuring efficient size reduction.

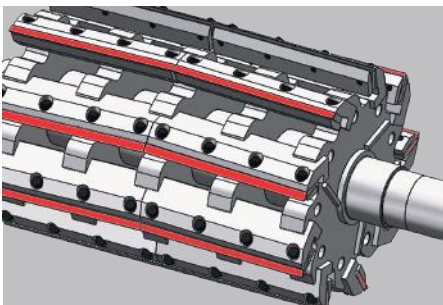

H9-Rotor

Similar to the S7, the H9 rotor is a closed design tailored for heavy-duty applications. It allows for the incorporation of knife supports made from highly wear-resistant steel, ideal for handling contaminated materials and extending service life.

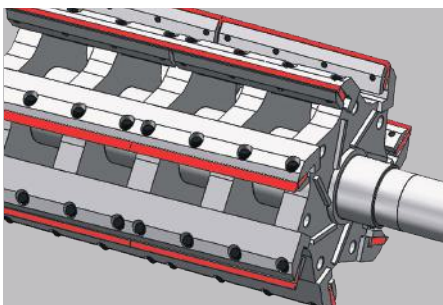

L7-Rotor

The L7 rotor is distinguished by its unique single cross-cut design, making it particularly effective in high-temperature applications, such as processing car tanks. This design facilitates efficient material breakdown under challenging conditions.

V-Cut Technology

Most rotors incorporate a V-cut design, which ensures consistent output material quality and guides the material towards the center of the cutting chamber. This technology enhances the granulation process, promoting uniform size reduction and efficient material flow.





GST:

The curved back wall of the cutting chamber ensures for aggressive ingestions while also avoiding blockages.

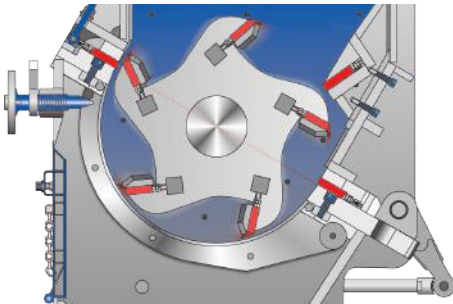

With Deflection Wedge

The removable deflection wedge houses a third stator knife. It allows easy and fast adjustments of the machines aggressively.

The deflection wedge alters the infeed of the machine and moves the first cut to the 2 o' clock position. Well suited for heavy thick walled parts such as lumps or pipe. Due to the added stator knife it increases the number of cuts per revolution increasing the output on light material such as film.

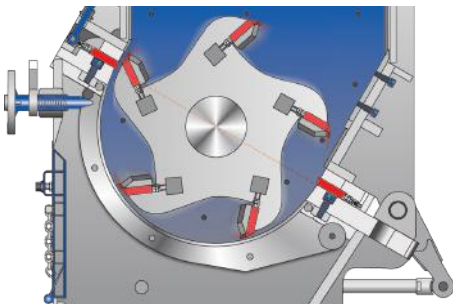

Without Deflection Wedge

The infeed is very strong and aggressive, the first cut will happen at the 4 o' clock position. Well suited for bulky materials, such as canisters or pales.



A variety of options – excellent results

Soundproofing for Inhouse installation of granulators



To ensure a safe working environment **ZERMA** offers various options to reduce the noise emitted from the granulators. All GSC models feature a sound dampening enclosure as a standard as well as sound dampening tunnels on the belt conveyors. GSH heavy duty granulators can be placed into custom sound insulating rooms which also offer enough space for the material blowers.



To minimize the needed floor space and make the machine easy to move the control cabinet is integrated into the machines soundproof housing.



GST, GSC:

In order to keep the machines as compact as possible, the motor and opening system are integrated into the sound dampening enclosure of the machine.

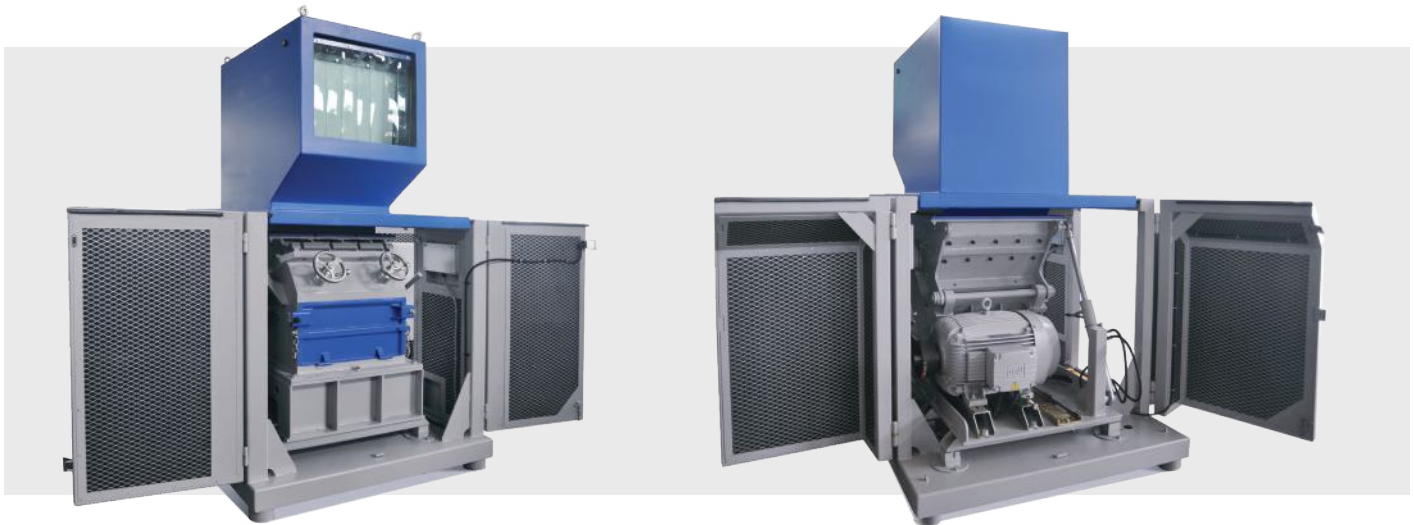

The right machine for every application

Technical specifications – overview

| | Model | Diameter | Width in mm | kW |
|------------------|----------|----------|-------------|------|
| GST | 250/300 | 250 | 300 | 7,5 |
| | 250/450 | 250 | 450 | 7,5 |
| | 250/600 | 250 | 600 | 11 |
| GST | 400/600 | 400 | 600 | 22 |
| | 400/1000 | 400 | 1000 | 30 |
| GSC / GSE | 300/300 | 300 | 300 | 7,5 |
| | 300/600 | 300 | 600 | 11 |
| | 300/1000 | 300 | 1000 | 18,5 |
| GSC / GSE | 500/500 | 500 | 500 | 30 |
| | 500/700 | 500 | 700 | 37 |
| | 500/1000 | 500 | 1000 | 45 |
| | 500/1400 | 500 | 1400 | 45 |
| GSC / GSE | 700/700 | 700 | 700 | 45 |
| | 700/1000 | 700 | 1000 | 55 |
| | 700/1400 | 700 | 1400 | 55 |

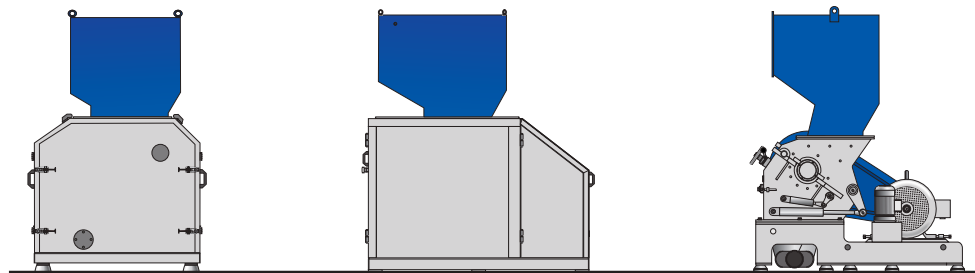

GST

GSC

GSE

| | Model | Diameter | Width in mm | kW |
|------------|------------|----------|-------------|---------|
| GSH | 350/500 | 250 | 500 | 22 |
| | 500/600 | 500 | 600 | 55 |
| | 500/1000 | 500 | 1000 | 55 |
| | 600/800 | 600 | 800 | 75 |
| | 600/1600 | 600 | 1600 | 132 |
| | 700/1000 | 700 | 1000 | 90 |
| | 800/1200 | 800 | 1200 | 132 |
| | 800/1600 | 800 | 1600 | 160 |
| | 800/2000 | 800 | 2000 | 2 x 160 |
| | 1100/1200 | 1100 | 1200 | 200 |
| | 1100/2400 | 1100 | 2400 | 2 x 200 |
| | GSP | 600/500 | 600 | 500 |
| 560/700 | | 560 | 700 | 55 |
| 560/1000 | | 560 | 1000 | 75 |
| 800/800 | | 800 | 800 | 90 |

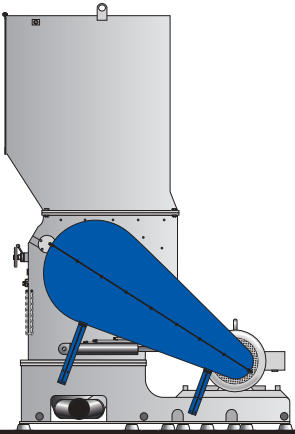

GSH

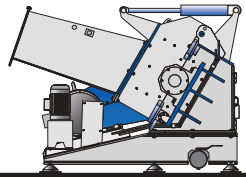

GSP

Wide range – great results

The right fit for any application

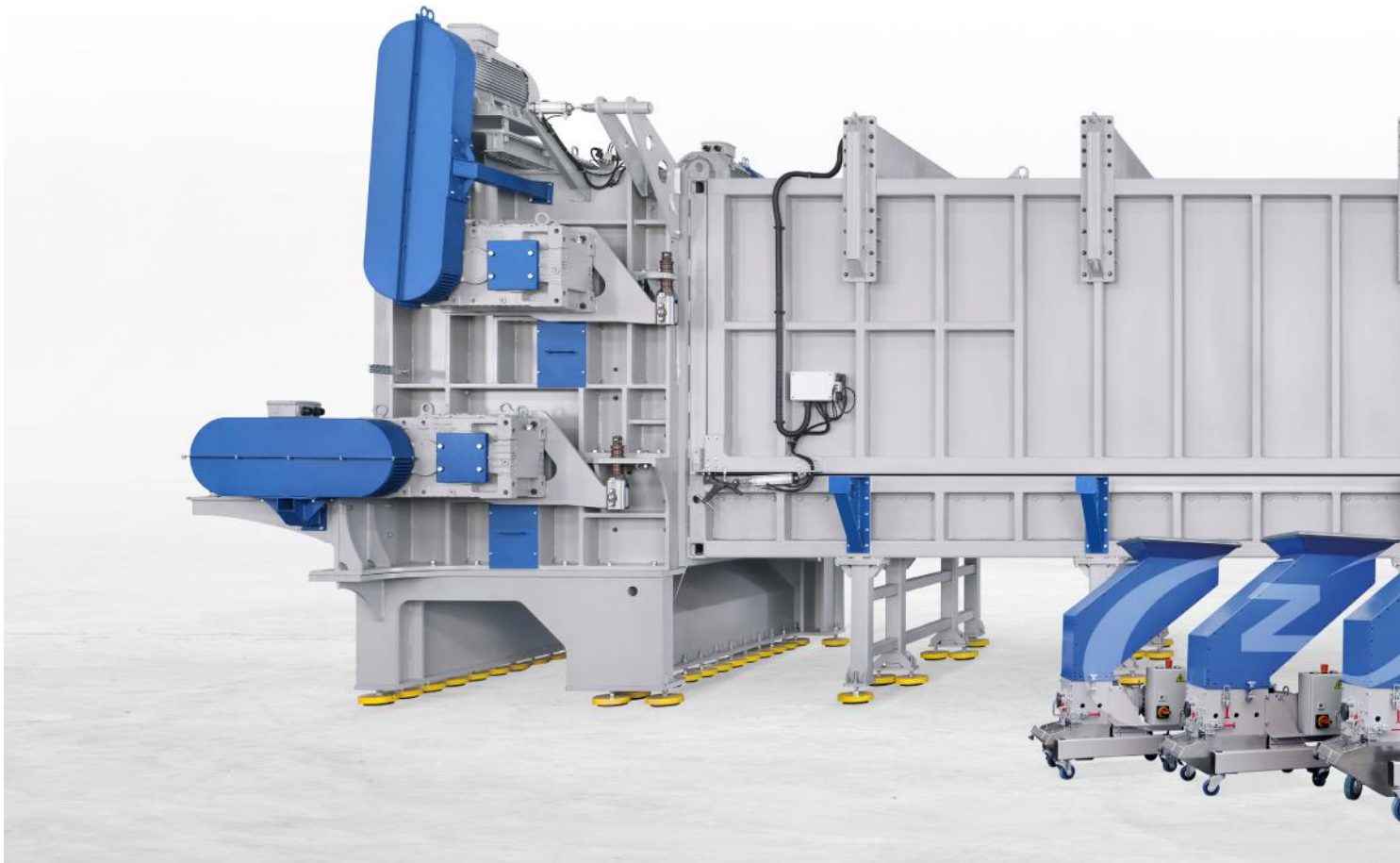

With more than 70 years of experience, **ZERMA** is one of the leading manufacturers of high quality size reduction machinery. With the wide range of machines **ZERMA** covers the whole spectrum of plastic size reduction applications.



ZERMA – The Home of Size Reduction



Close to our customers

The global ZERMA network of branches and distributors



ZERMA America
9120 Centerlinks Commerce Dr. Suite 4
Fort Myers · Florida · 33912
Phone: 239-219-1100 · sales@zerma-america.com



www.zerma-america.com