



Shredders

ZBS · ZCS · ZSS · ZHS · ZXS · ZRS

ZERMA

The Home of Size Reduction

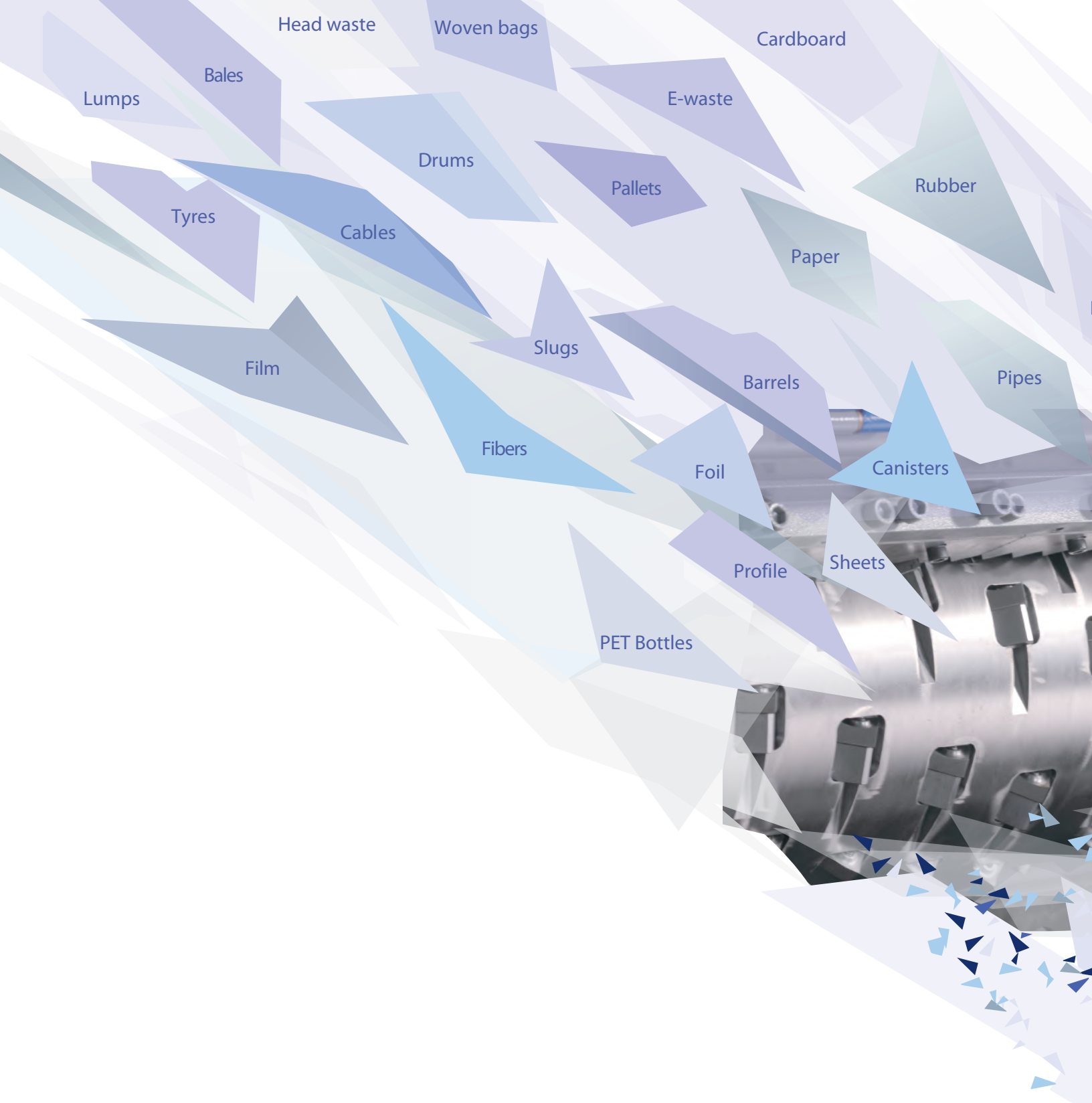

Head waste

Woven bags

Cardboard

Lumps

Bales

E-waste

Drums

Pallets

Rubber

Tyres

Cables

Paper

Film

Slugs

Barrels

Pipes

Fibers

Foil

Canisters

Profile

Sheets

PET Bottles

Shredders can be used to process a wide variety of materials, from plastics to wood, paper, and general waste streams. Mostly they are used together with a granulator to achieve a smaller output size.

The Home of Size Reduction

ZERMA has long been a leading supplier of size reduction equipment for the plastic industry mainly focusing on in house and central granulators. Adding single shaft shredders to the portfolio to supply a complete range of size reduction machinery to handle any task in plastics recycling and designing a system where each component is matched perfectly to the application and works hand in hand.

Purgings

Scrap

Typical applications of single-shaft shredders

Applications

ZERMA single shaft shredders have been designed as dependable machines to be used in a wide variety of applications. They can achieve high outputs while being able to handle larger and stronger input materials. Combining a heavy rotor with a slow speed and high torque drive also helps reduce energy costs by avoiding amperage peaks.

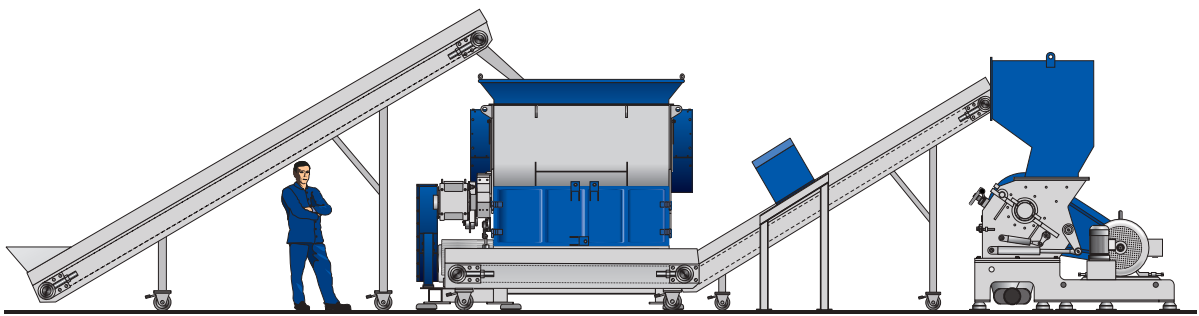

ZSS / ZPS / ZIS Single Shaft Shredder

The ZSS / ZPS and ZIS shredders have been designed for a wide variety of applications. Depending on input material and the recycling process, the shredded material will be used directly or will be further reduced, for example in a GSH granulator.



ZCS Single Shaft Shredder

The ZCS series of machines combine a shredder and a granulator in a stacked system. They offer the same performance as a two stage system in a smaller footprint. The series is especially well suited for in-house recycling applications.

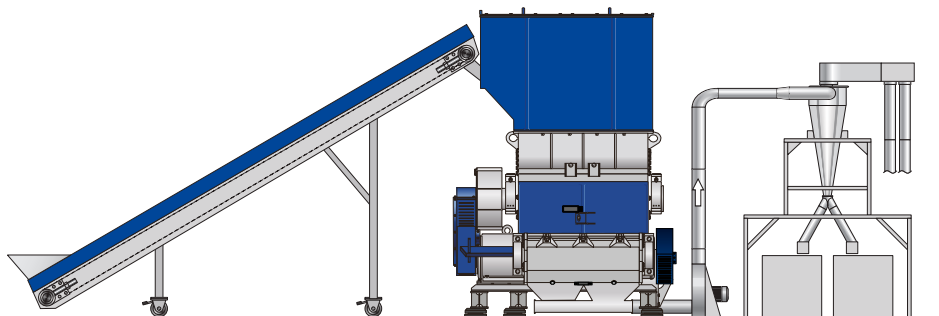

ZRS - Pipe / Profile Shredders

The main focus of the ZRS shredders lies on the shredding of long lengths of large diameter plastic pipes or bundles of smaller pipes and profiles. The unique design of the machine allows easy feeding and safe processing of these long pipes. Adding **ZERMA** granulators and pulverizers offers a complete recycling system tuned to deliver the best performance.

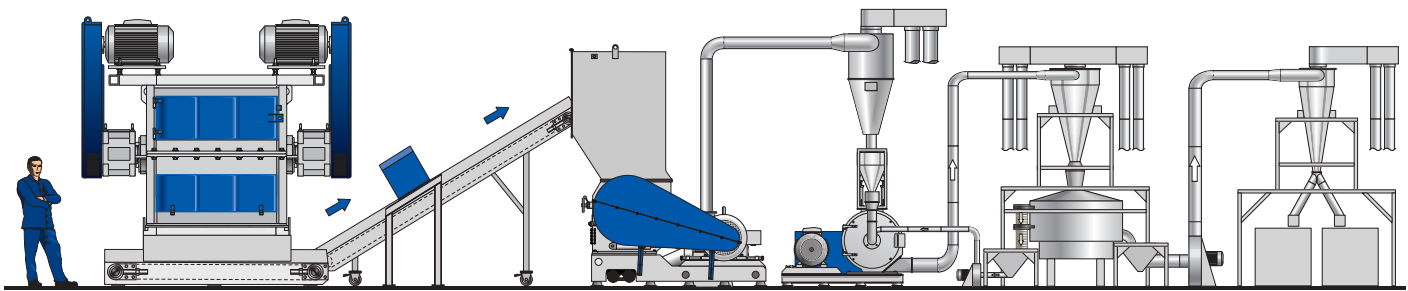

ZXS Single Shaft Shredder

The ZXS shredders are built for the most demanding and high throughput applications in recycling, ranging from recycling of large petrochemical lumps to MSW waste streams.

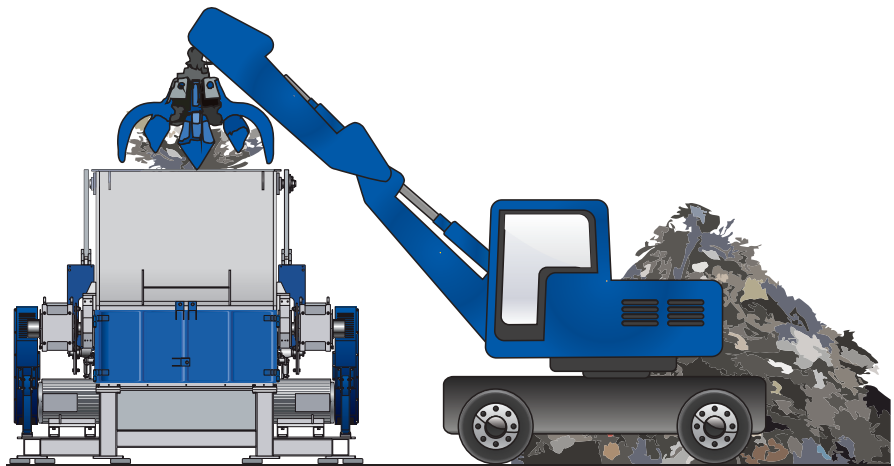

Advanced engineering – great results

The right machine for today's recycling requirements



ZBS

ZSS / ZPS / ZIS

ZHS

Like all **ZERMA** machines the shredders are engineered to handle heavy use and continuous operation, easy to service and ensure performance and great results.

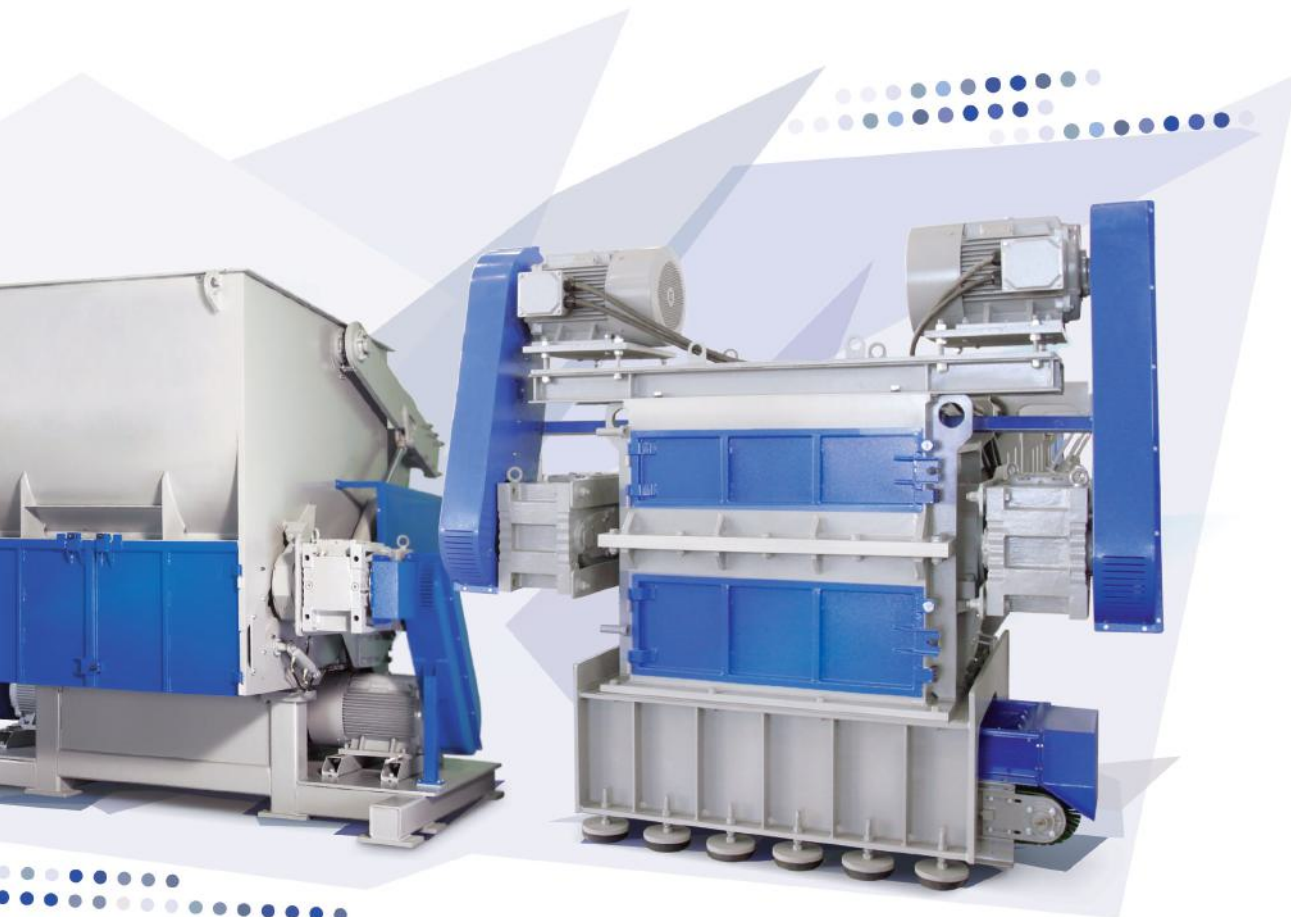

ZXS

ZRS

- Sturdy design
- Low rotor speed – high torque
- Potent hydraulic feeder
- Advanced controls – easy integration with other ZERMA equipment.

ZERMA range of shredders

ZBS Series – Affordable Shredder for Lumps & Purgings

The ZBS series shredders are single shaft shredders with tangential infeed eliminating the need for a hydraulic feeding system. The compact and maneuverable design combined with the 'plug and play' controls give this machine total flexibility and ease of use. Like the bigger brothers in the ZSS series, the ZBS are equipped with outboard bearings, 310 mm diameter flat E rotors with 600 mm or 850 mm width, driven by an oversized geared motor, and incorporate the proven ZERMA knife holder and knife design. The user friendly design allows for simple and efficient cleaning and maintenance.

The low rotor speed of 60 rpm combined with the compact design of the ZBS shredders makes it possible to shred lumps at a low noise level. The machines can be fed manually or by conveyor. Material discharge can be done via conveyor or into a drop box.



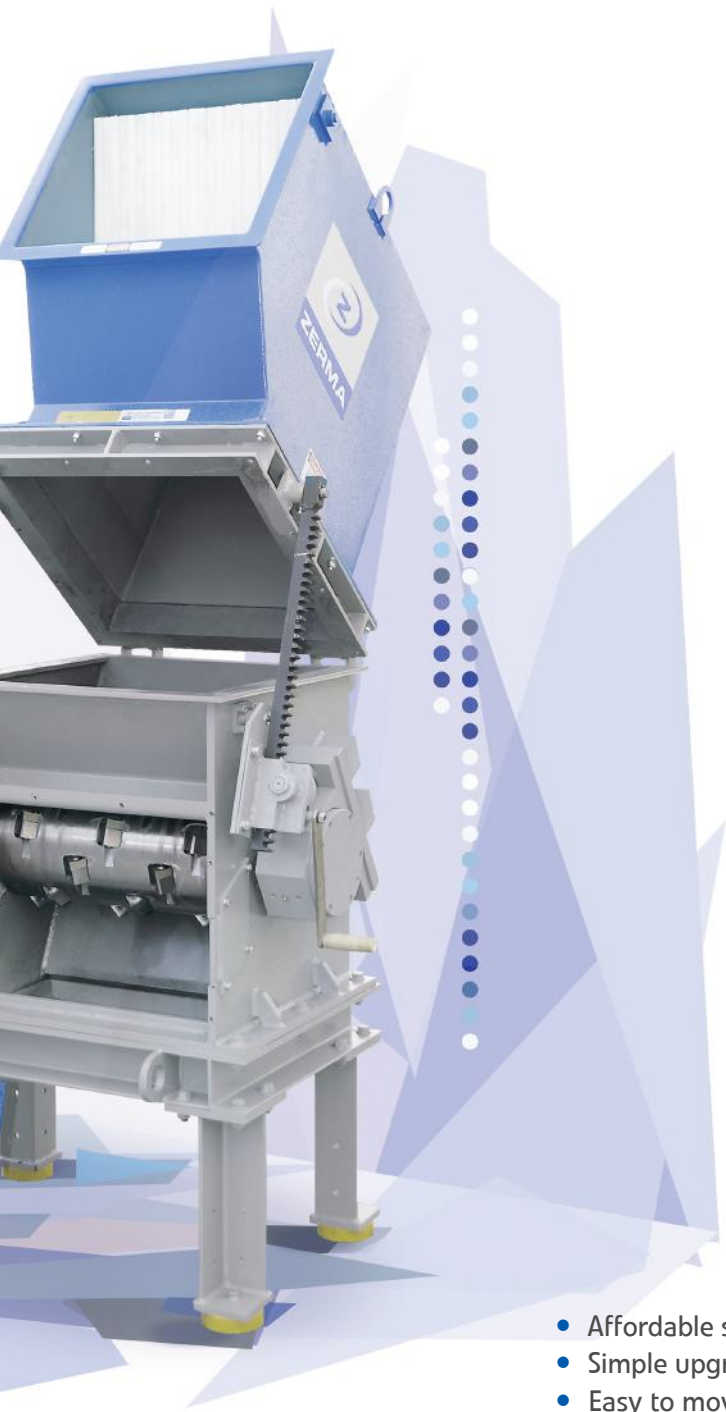

- Affordable solution for small lumps
- Simple upgrade for existing granulation system
- Easy to move and place
- Tangential infeed avoids the need for a hydraulic pusher
- Small footprint
- Low energy consumption

Small and effective - best results

ZCS Series – Shredder / Granulator Combination

The **ZERMA** ZCS series revolutionizes production waste processing by integrating a shredder and a granulator into a single compact system. It features a robust shredder equipped with a 400 mm diameter E rotor and a ZERMA granulator, complemented by a large hopper and a powerful pusher that facilitate the processing of various materials. The shredder and granulator are sized to work seamlessly together, providing uniform output. Due to the small footprint the ZCS series is an ideal solution for in house recycling applications.

Optionally, a magnetic grid can be placed between the shredder and granulator to remove common metallic contaminants from the material stream.





- Compact space saving design
- Low noise emission
- Versatile size reduction concept
- Flexible discharge options

The practical solution – with the best results

ZSS / ZPS and ZIS Series – Shredder with speed swing ram design

The ZSS / ZPS and ZIS shredders feature a powerful two speed swing ram design, eliminating the risk of blocking and wearing out of guide rails.

The large diameter **ZERMA** rotor with its unique knife and knife holder design are able to handle various types of input material with ease. Oversized outboard bearings and a hydraulic screen cradle are standard and ensure dependable performance and easy maintenance. The shredders can be tailored to specific applications with rotor cooling, hard facing, and other wear options.

Optionally the ZSS shredders can be equipped with heavier and taller hydraulic ram. This ZPS style ram improves the handling of heavy parts such as pipes or heavy purgings.

The ZIS shredders are designed with a larger internal volume to handle large bulky objects such as IBCs, barrels and pallets.



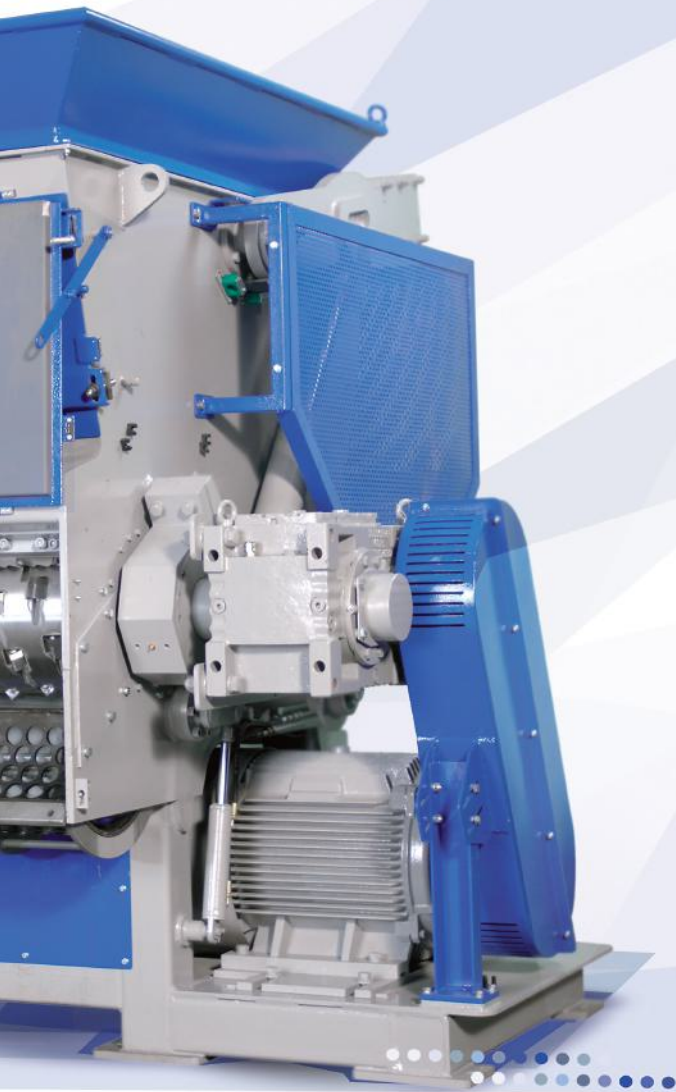

- Oversized gearboxes with high torque
- Sturdy welded steel construction
- Hydraulic feeders without guide rails
- Bolted knife and knife holders
- 35 % more space in the cutting chamber / ZIS Series

The sturdy allrounder – for every use

ZHS Series – Shredder with angled hydraulic ram

ZERMA ZHS shredders are single shaft shredders featuring an angled hydraulic ram suitable for a wide range of material shapes and sizes. The ZHS shredders are equipped with a **ZERMA** E style rotor and knife holder system. The final size of the material is determined by the screen which can easily be changed based on requirements.

The ZHS shredder can be tailored to individual requirements, which includes different drive powers, knife configurations as well as discharge options.

The ZHS+ series is an upgrade to the ZHS series, featuring a 600 mm diameter rotor and the option for 50 mm rotor knives. These improvements equip the ZHS+ series with superior capabilities, enabling it to tackle challenging applications and deliver significantly higher outputs.

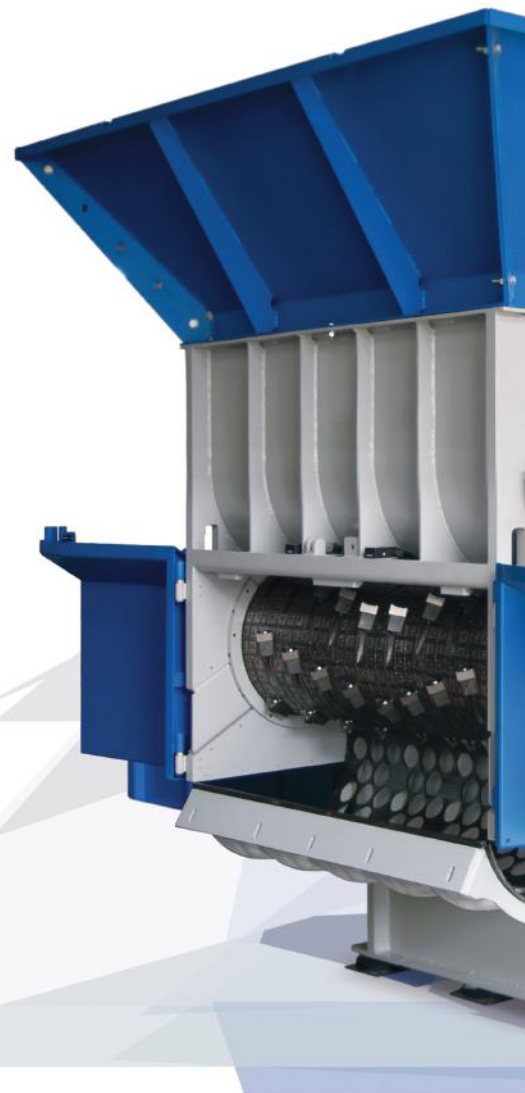



- Large feeding hopper
- Robust welded steel construction
- Low speed operation
- Advanced rotor / knife mounting system

Universally use – affordable performance

ZXS Series – Shredder with large diameter rotors

The ZXS shredders feature large 750 mm diameter rotors driven by heavy industrial gearboxes. As with all **ZERMA** shredders they feature a unique bolted knife and knife holder design to ensure easy maintenance and flexibility. The heavy swing ram combined with 11 kW two speed hydraulic system guarantee high outputs even on the heaviest materials.

The ZXS-T models come with larger drives and complete wear protection to process multiple tons per hour of waste, tires, or MSW streams.



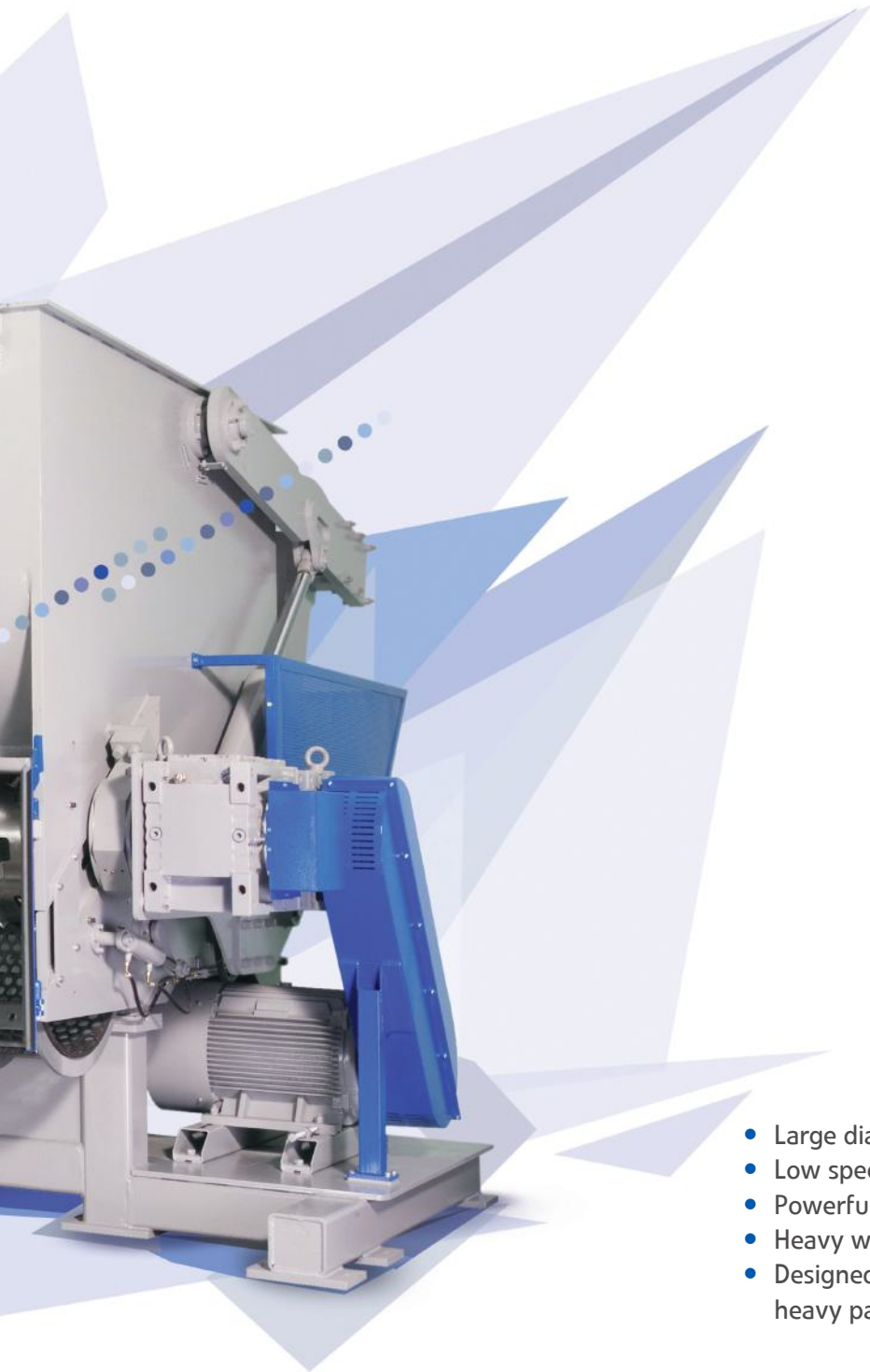

- Large diameter rotor (750 mm)
- Low speed, high torque twin gear drive
- Powerful two speed hydraulic
- Heavy welded design
- Designed for high throughput rates and very large heavy parts

For high throughput applications

ZRS Series – Shredder for large pipes and profiles

The ZRS shredders are the world's first single shaft shredders specifically designed to handle large diameter pipes without the need for pre cutting. Since their introduction they became the per se standard for pipe shredding and are used by the leading pipe manufacturers all over the world. More than 200 installations demonstrate our technological leadership in this industry and continuing innovation based on market demands and customer feedback.





- Large diameter rotor
- Safe feeding of long (6 m) pipes
- Ability to process mixed diameter pipes with a wide range of thicknesses
- Integrates with ZERMA granulator and pulverizer to create a turn key pipe recycling solution

Great technology - great results

Technical details – well thought out and efficient



All shredders are equipped with a flat E-style rotor featuring machined pockets for the bolt-in knife holders and knives. The hydraulically lowered screen cradle ensures easy knife maintenance and screen changes.

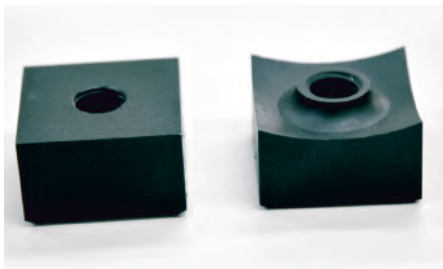

ZERMA shredders are available with different knife designs to fit specific applications. All knives are square and can be turned once one side is worn down.

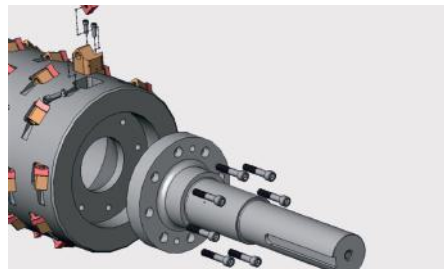

Rotor shafts and knife holders are bolted into the rotor to ensure easy reparability in case of accidents as well as acting as a safety breaking point to prevent further damage to the machine.



For heavy wear applications or abrasive materials, weld-on hard facing can be applied to the rotors and knife holders. Specially designed Tungsten Carbide blades can be used to extend the knife life when processing tires, MSW, or other contaminated materials.





The ZSS / ZPS and ZXS shredders benefit from the sturdy swing ram. The design works without the need for guide rails avoiding the risk of clogging and wear. Two powerful hydraulic cylinders combined with the serrated ram plate ensure a secure grip and good ingestion on all materials.



The internal ram design on the ZIS series allows the cutting chamber volume to be increased while keeping a small footprint. This makes the ZIS ideal for shredding big volume parts.



The ZRS pipe shredders are equipped with a special feeding trough sized to take pipes up to 6 m length. A powerful hydraulic ram forces the pipes into the rotor.



All ZERMA single shaft shredders are equipped with a serrated plate at the front of the hydraulic pusher. This helps ensure constant feeding of the material into the rotor with a variety of materials.

Advanced engineering – great results

Technical details



All shredders are equipped with a powerful two speed hydraulic system. This system ensures maximum pressure when feeding material into the rotor and high speeds on the backstroke and running under low load.



The hydraulic rams in the ZHS and ZRS series shredders are guided by steel rails and large oversized steel rollers. This ensures dependable performance, reduced risk of jams and low wear.

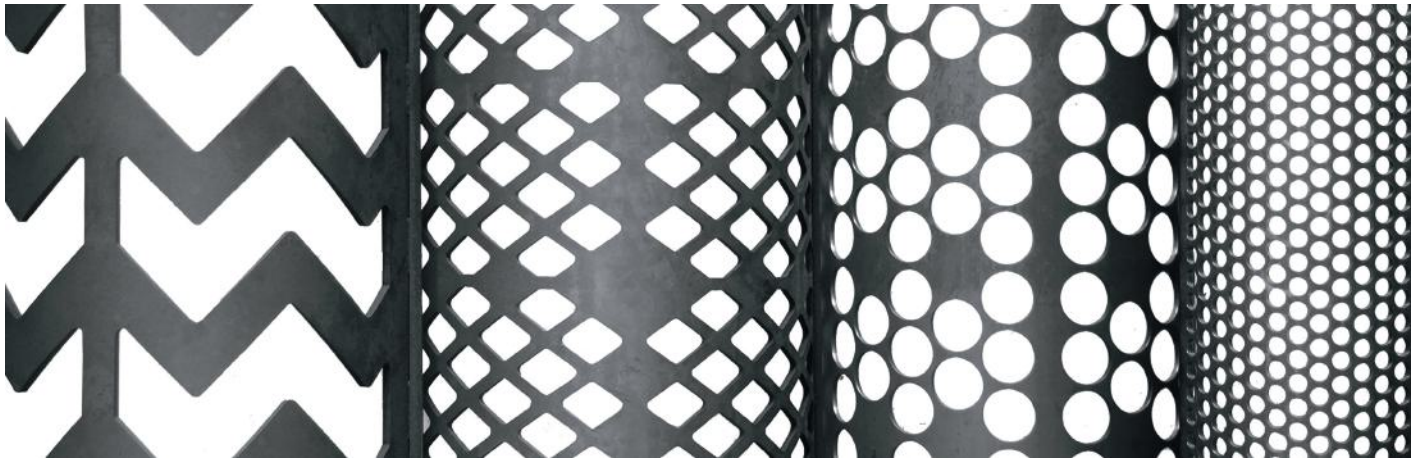

The shredders can be equipped with a variety of screen designs to tailor the machine to different materials. Common designs include round holes, square, diamond and zig-zag.

When processing contaminated or abrasive materials the screens can be manufactured from highly wear resistant materials.



For the processing of thin or fibrous material the segmented floor and pusher on the ZHS series shredders can prevent material from getting lodged under the hydraulic ram, avoiding jams and excessive wear.

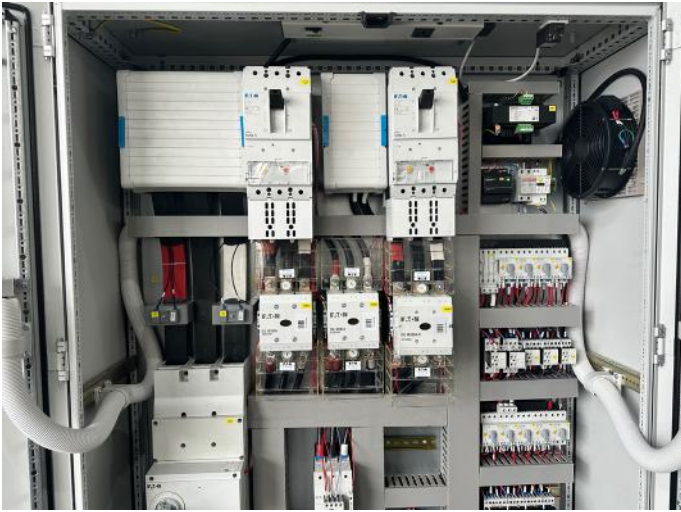

ZERMA's shredders come equipped with integrated controls, designed to meet the latest international safety standards. This ensures not only superior performance but also a high priority on operator safety. The advanced control systems enable seamless integration of multiple ZERMA machines into a unified system, all controllable from a single touch screen interface. This centralized control feature simplifies operations, enhancing efficiency and user-friendliness. Operators can effortlessly adjust settings, monitor performance, and manage various aspects of the process. ZERMA's capability to integrate the entire size reduction process highlights its commitment to delivering cutting-edge solutions that are safe, efficient, and tailored to meet the demands of modern recycling operations globally.



In recycling operations that utilize two-stage systems, which consist of a shredder combined with a granulator, it is recommended to integrate metal detection and separation. To maintain continuous processing, ZERMA offers the option to integrate a metal detector and an

automated discharge flap into the belt conveyor. This flap automatically discharges metallic contamination from the product flow, eliminating the need for manual intervention.

Advanced engineering – great results

Technical specifications – overview

	Model	Diameter	Width in mm	kW
ZBS	600	310	560	11
	850	310	840	18.5
ZCS	600	310	560	11 + 7.5
	1000	400	1000	30 + 15
	1400	400	1400	45 + 22
ZSS	850	457	850	37 / 55
	1200	457	1130	55
	1500	457	1410	75
	2000	457	1970	2 x 55
ZHS	850	400	850	22
	1100	400	1100	30
	1400	400	1400	45
	1700	400	1700	55
	2000	400	1960	75

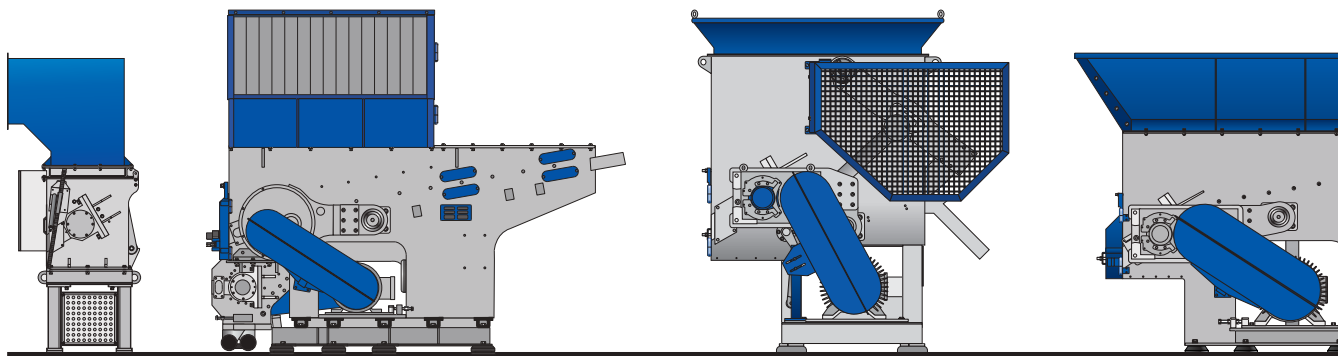

ZBS

ZCS

ZSS

ZHS

	Model	Diameter	Width in mm	kW
ZHS+	1500	600	1400	90
	2000	600	1960	110
	2600	600	2520	2 x 90
ZXS	1500	750	1600	2 x 75
	2000	750	2000	2 x 90
	3000	750	2800	2 x 132
ZRS	800	850	800	2 x 37
	1000	980	1000	2 x 45
	1500	1430	1500	2 x 55
	2000	1970	2000	2 x 75
	2600	2 x 1300	2600	4 x 55

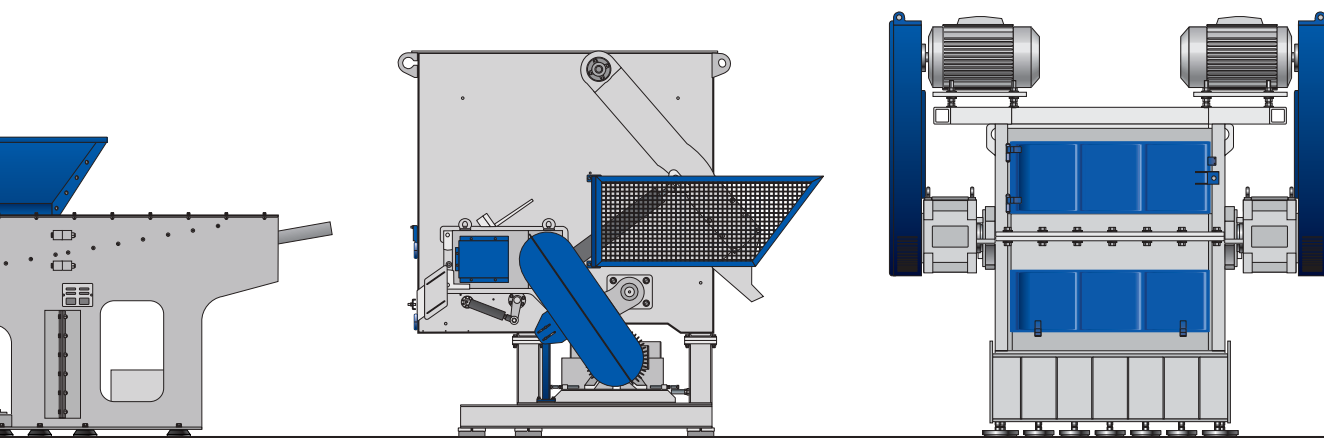

ZXS

ZRS

Wide range – great results

The right fit for any application

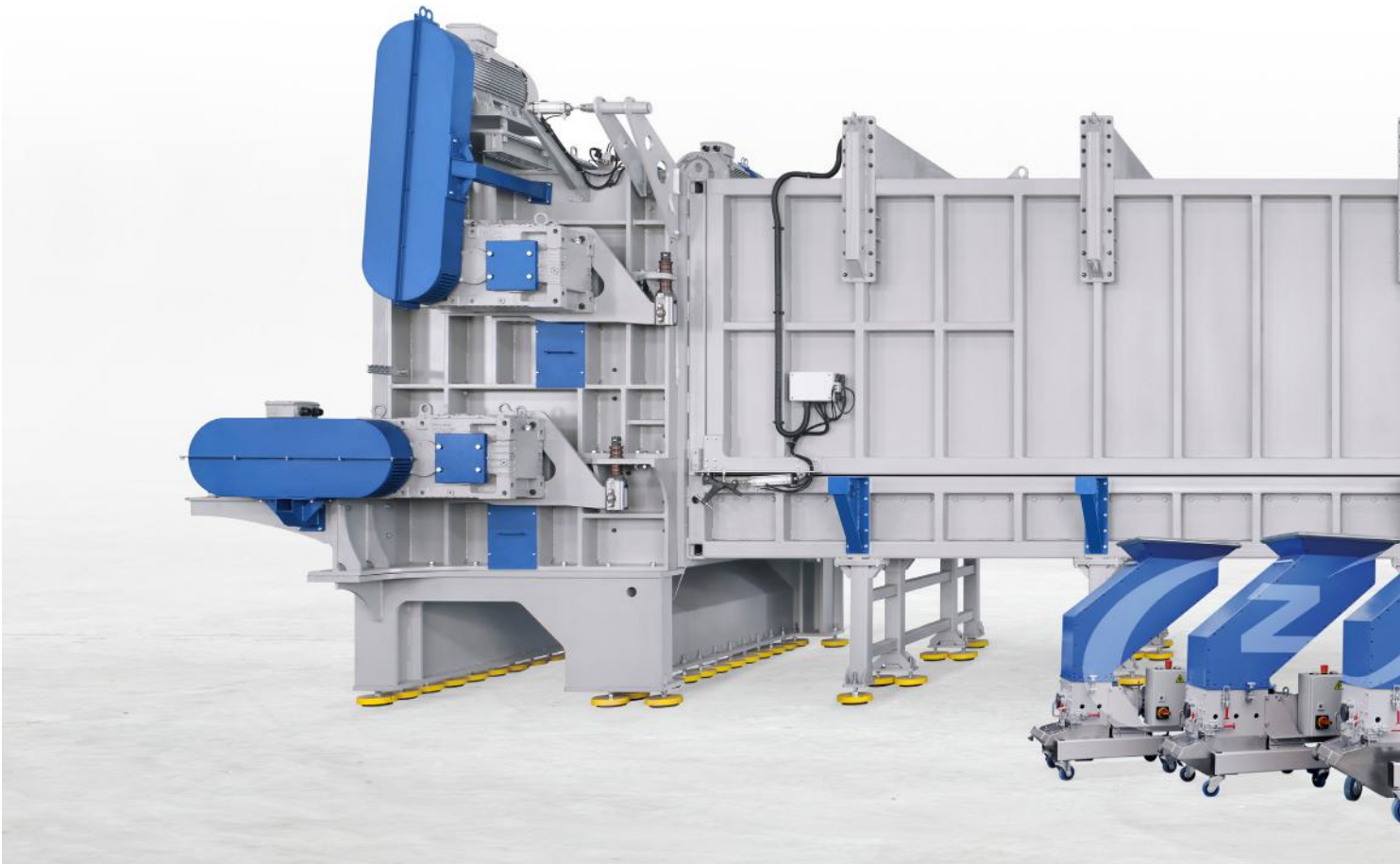

With more than 70 years of experience, **ZERMA** is one of the leading manufacturers of high quality size reduction machinery. With the wide range of machines **ZERMA** covers the whole spectrum of plastic size reduction applications.



ZERMA – The Home of Size Reduction



Close to our customers

The global ZERMA network of branches and distributors



ZERMA America

9120 Centerlinks Commerce Dr. Suite 4
Fort Myers · Florida · 33912
Phone: 239-219-1100 · sales@zerma-america.com



www.zerma-america.com